

# Quick Start Guide

## ≡ 快速启动指南 ≡

**⚠ WARNING  
注意事项**

1. Please refer to this Guide for initial printer setup.
2. Hot! Avoid touching the heating nozzle in operation.
3. Moving parts in the printer may cause injuries. Do not wear gloves or other sources of entanglement in operation.

1. 请参照本指南完成打印机的初始准备。
2. 高温危险！打印机喷嘴在工作时会被加热，操作时请避免接触！
3. 可动部件可能会造成卷入挤压和切割伤害。操作机器时请不要佩戴手套或缠绕物。

**⚠ Safety Notice  
安全提示**

Do not power on the printer until installation is completed.  
请勿在打印机安装完成之前通电。

**⚠ LEGAL STATEMENT  
法律申明**

Users are not authorized to make any modifications to this Quick Start Guide. Flashforge shall not be held responsible for any safety incidents resulting from the disassembly or modification of the equipment by the customer. No one is allowed to modify or translate this Guide without Flashforge's permission. This Guide is protected by copyright, and Flashforge reserves the right of the final interpretation of this Guide.

用户无权对此使用手册进行任何修改。  
客户若自行拆装或改造设备造成任何安全事故，闪铸集团概不负责。  
未经闪铸集团允许，任何人不得对该手册进行修改或翻译。本手册受版权保护，闪铸集团对本手册保留最终解释权。



## Thank you for choosing Flashforge!

Even if you are an experienced user or have used our products before, we highly recommend reading this Guide carefully. The instructions and precautions provided will help ensure proper installation and smooth operation.

To help you get the most out of your printer, you can also find operating guidance and practical tips through the following resources:



Scan the QR code to view a detailed unboxing guide and get started quickly.  
<https://wiki.flashforge.com/en/creator-series/creator-5-series/manual/unboxing-your-creator-5-pro>



Software: Download our official slicing software (Flash Studio Desktop) and mobile app (Flash Studio Mobile) from our website.  
<https://www.flashforge.com/pages/download-center>



Quick Start Tutorials: Visit the Flashforge Wiki for more tutorials on printer operation and maintenance.  
[wiki.flashforge.com](http://wiki.flashforge.com)

# Unboxing Instructions

1. Open the box and remove the top foam and the Quick Start Guide.

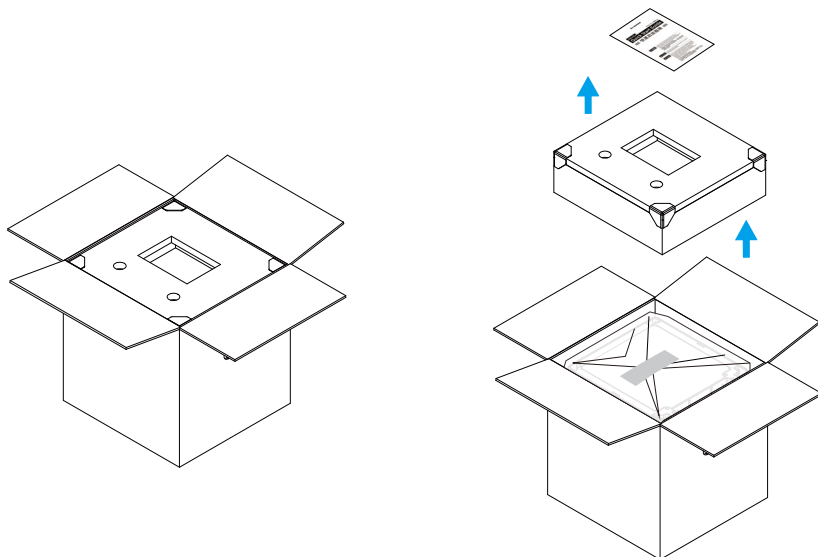

2. Lift the printer out of the box along with its packaging, and place it on a level surface.

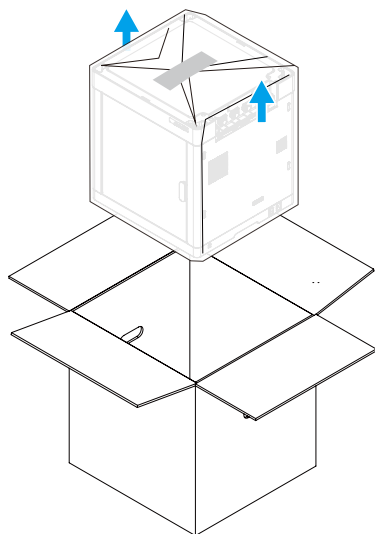

3. Remove the protective bag and the top cover. Then, take out the protective foam from inside the printer following the arrows.

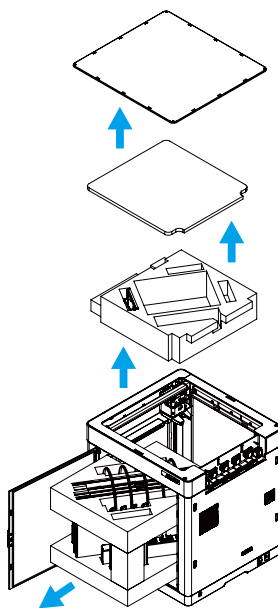

# Packing List



Top Cover Lid

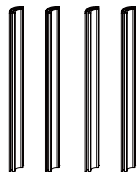

Top Cover Pillar\*4



Top Cover Front &  
Rear Panels



Top Cover Left &  
Right Panels

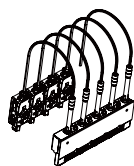

Extruder Dock  
Module



Filament



Power Cord

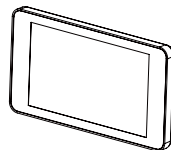

Display Screen

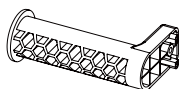

Spool Holder\*4

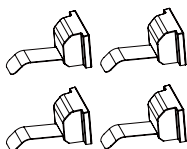

Nozzle Blocker\*4

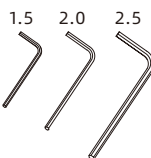

Allen Wrench

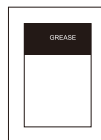

Grease

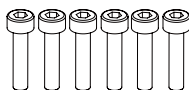

M3×14 \*4  
M3×16 \*2

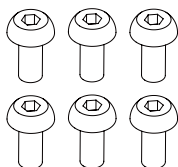

ST2.9×9.5 \*6

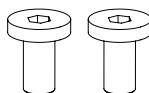

M3×6 \*2



Quick Start Guide

# Printer Components

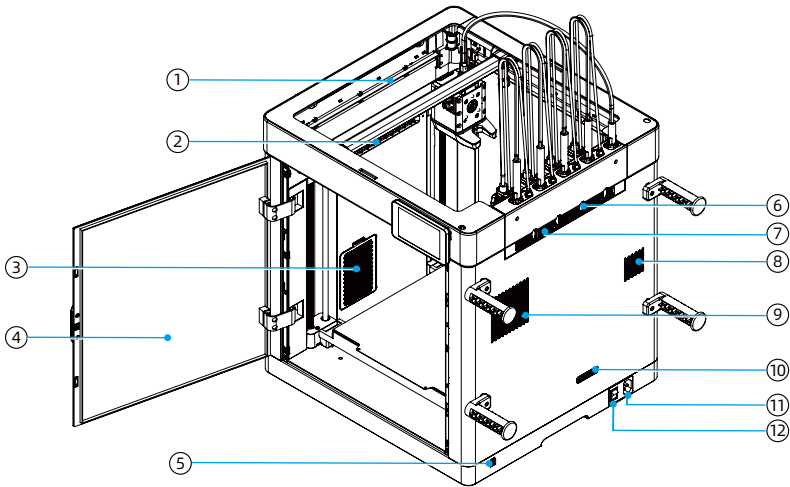

1. Chamber Light
2. Auxiliary Cooling Outlet
3. Air Filter
4. Front Door
5. External Communication Port
6. Filament Inlet
7. Extruder Cooling Vent
8. Power Supply Cooling Vent
9. Chamber Exhaust Outlet
10. Mainboard Cooling Vent
11. Power Socket
12. Power Switch

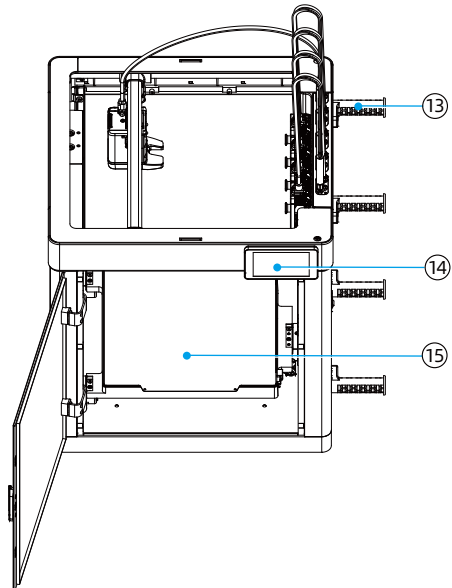

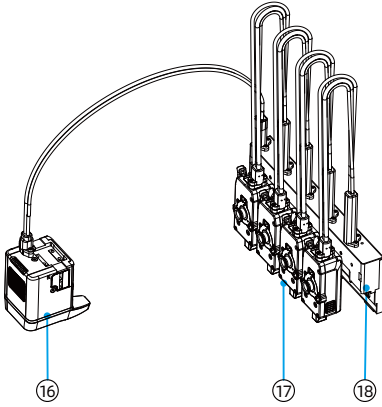

- 16. Extruder Mount
- 17. Extruder
- 18. Extruder Dock

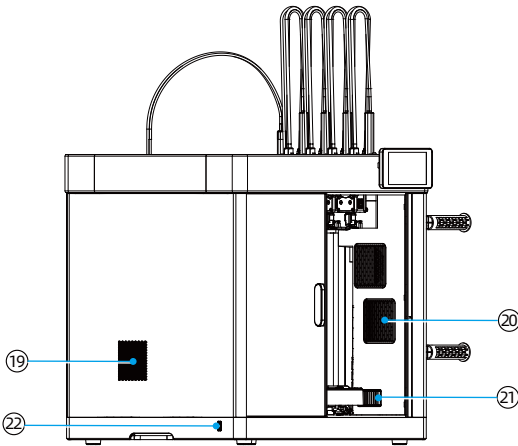

- 19. Chamber Cooling Intake
- 20. Chamber Heating Intake
- 21. Chamber Heating Outlet
- 22. USB Port

## Install the Display Screen

1. Align the slots on the back of the display screen with the mounting points on the printer. Then, attach the display screen as shown.

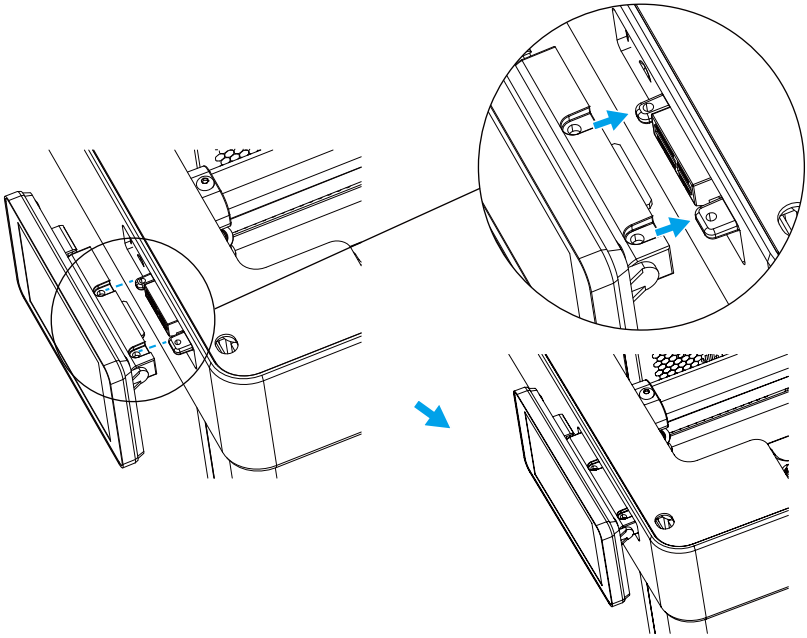

2. Secure the display screen using two M3×6 screws.

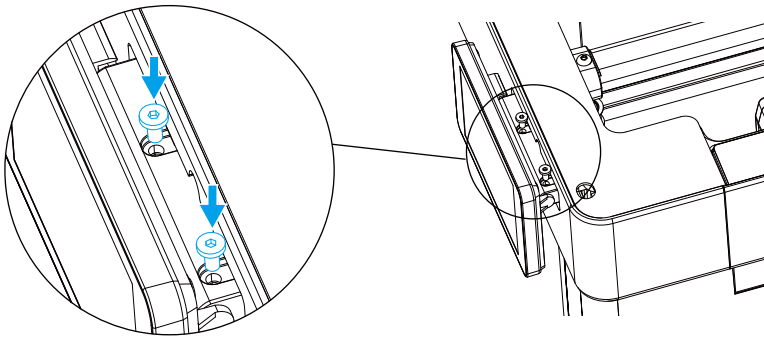

# Install the Extruder Module

1. Insert the four nozzle blockers into the slots of the extruder dock as shown.

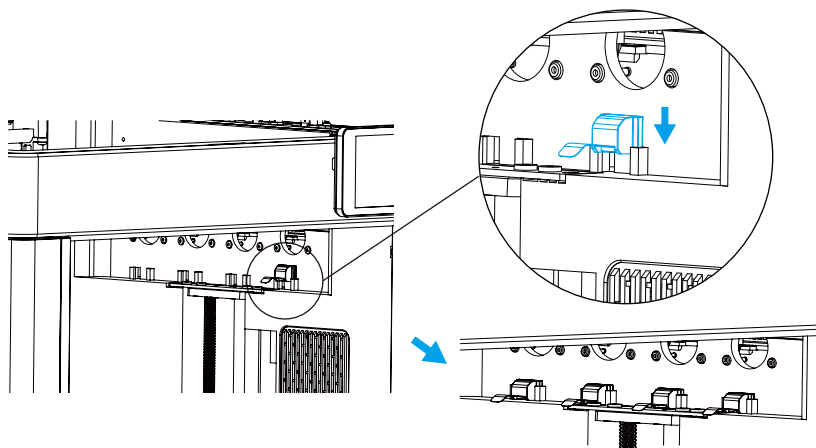

2. Align the extruder dock with the slot on the right side of the printer and insert it downward.

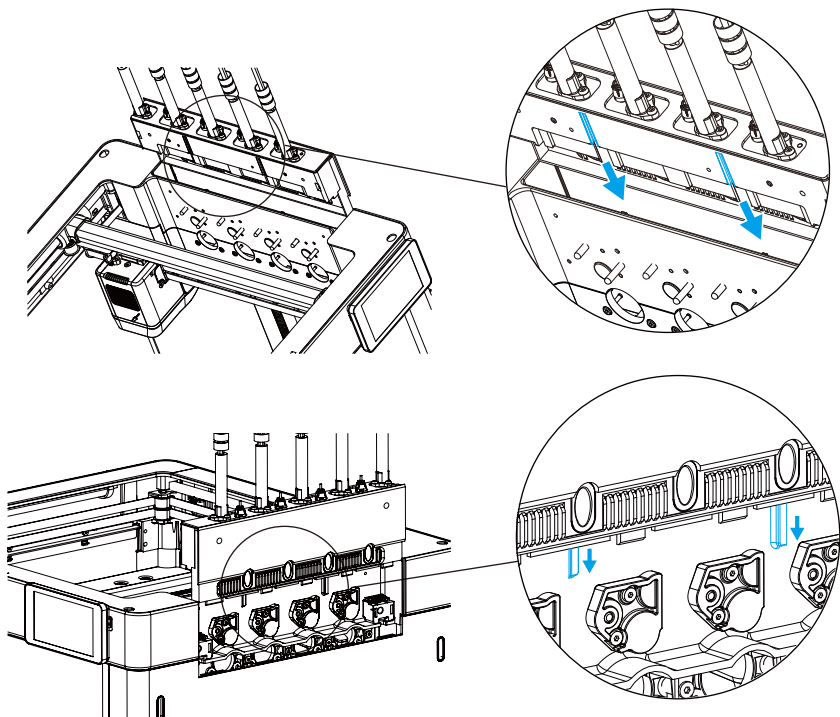

3. Secure the extruder dock using two M3×16 screws.

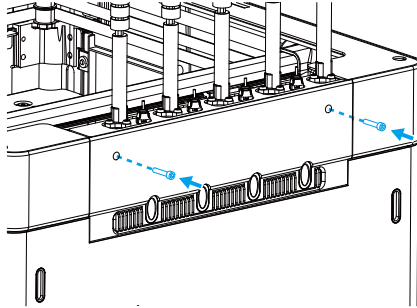

4. Mount the four extruders onto the extruder dock, aligning each with its corresponding positioning posts according to the order of the extruder connection cables.

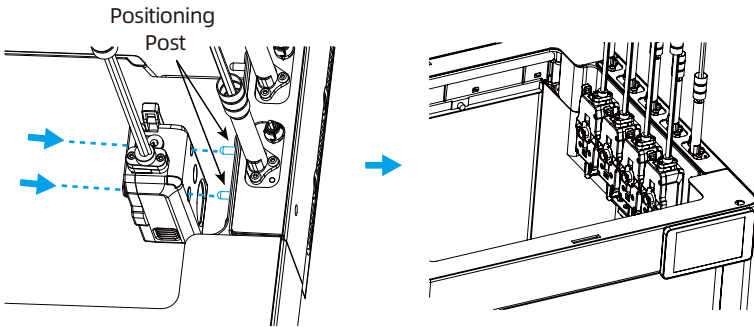

### Wiring Harness Installation & Connection Guidelines

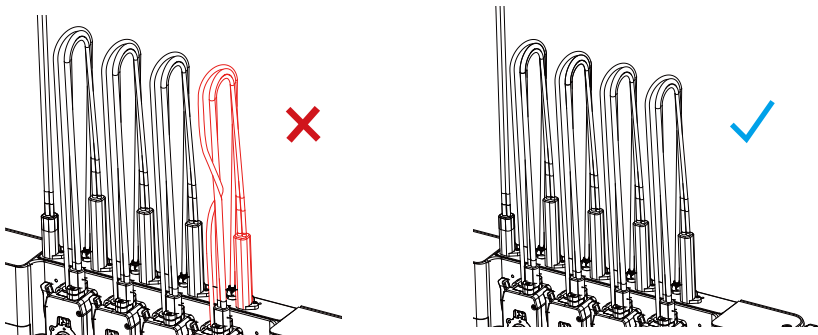

**Note**

Align the wiring harness with its natural curve and keep cables parallel to the filament guide tube at all times to prevent twisting or kinking.

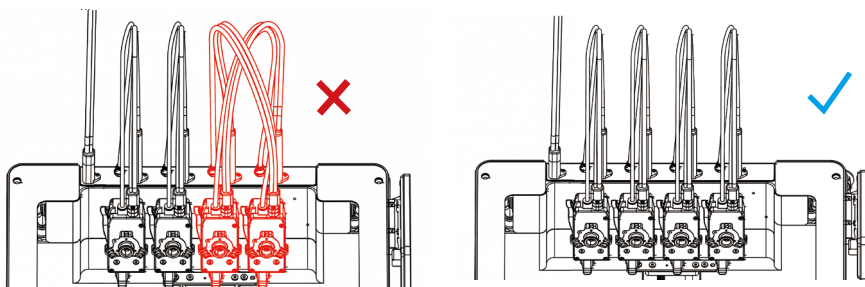

**⚠ Note**

Each extruder must correspond to its mount in the correct sequence. Incorrect connections may cause pickup errors. Do not cross-connect.

5. Connect the extruder mount cable to the communication port on the extruder mount. Once firmly inserted, secure it with two ST2.9×9.5 screws.

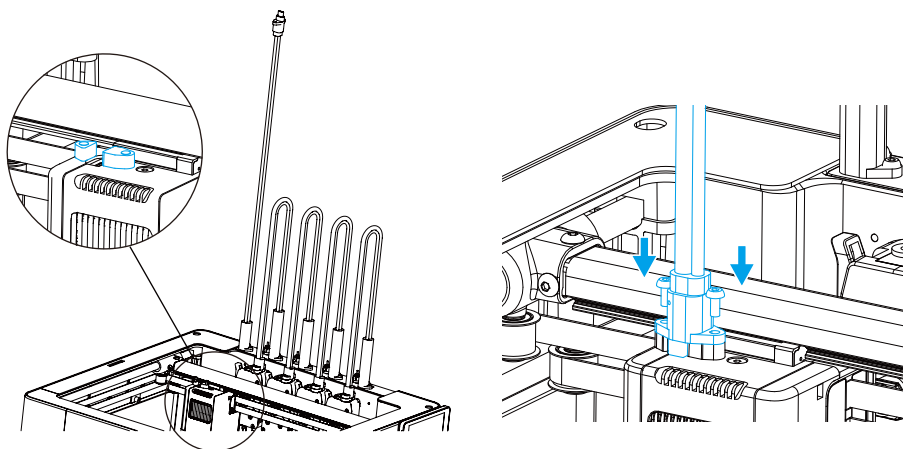

## Unlock the Print Bed

Use a 2.5mm Allen wrench to remove the three securing screws indicated by the arrows to unlock the print bed.

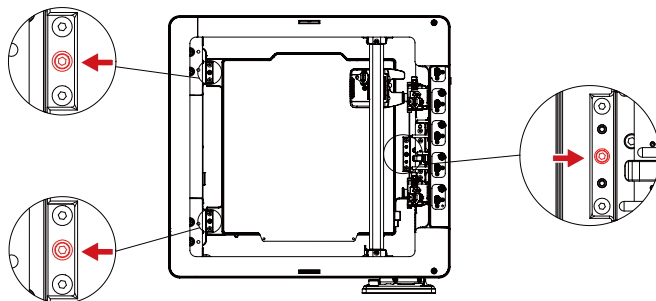

## Install the Top Cover

1. Slide each top cover panel into the grooves of the top cover pillars as shown. Make sure the sides with the clips are all facing the same direction during installation.

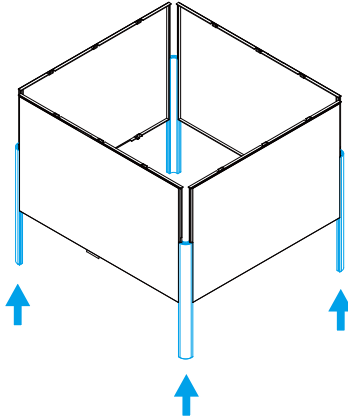

2. Align the top cover lid with the clips and press down until it snaps into place. Secure the lid using four ST2.9×9.5 screws.

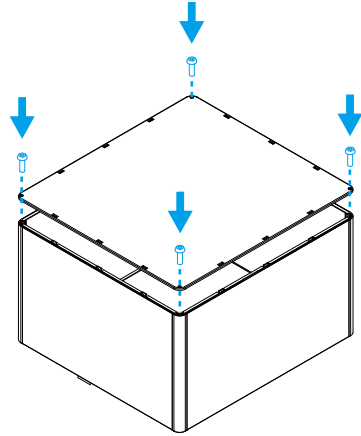

3. Once the top cover is assembled, position it onto the printer by aligning the positioning tabs on the front and rear panels with the corresponding holes on the printer.

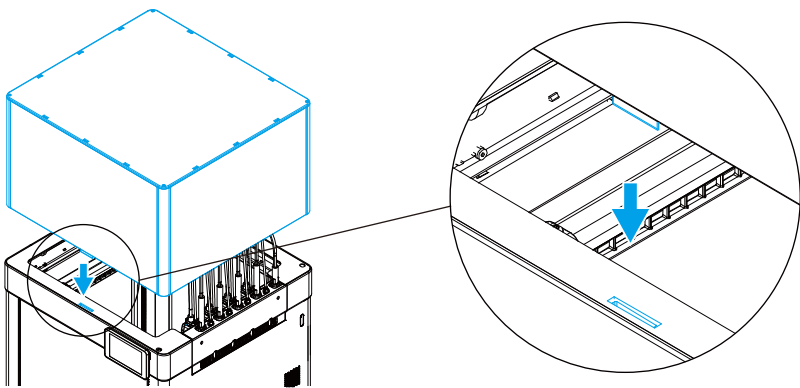

## Install the Spool Holder

Insert the spool holders into the four holes on the right side of the printer as shown, and secure them with four M3×14 screws.

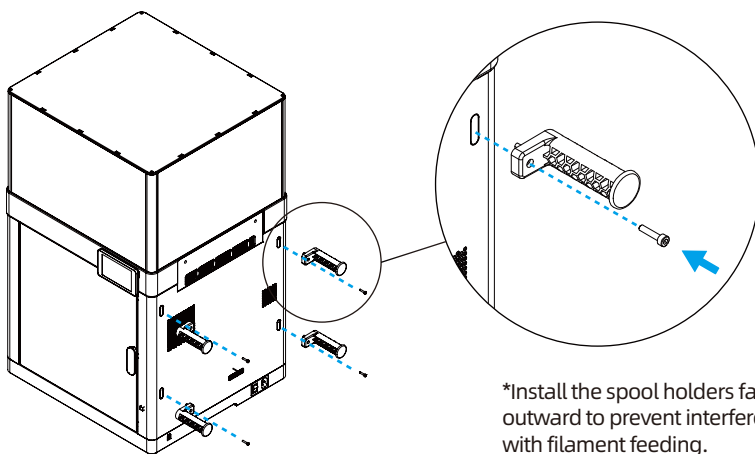

## First Power-On

**Note** Make sure all the steps above have been completed before turning on the printer.

1. Connect the power cord and switch on the printer.

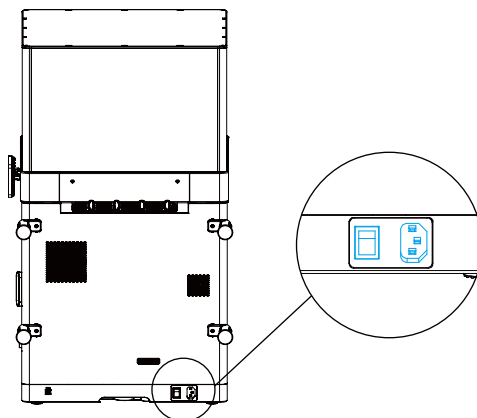

2. Upon first startup, the printer will launch the Setup Wizard. Follow the on-screen instructions to complete the initial setup.  
Select Language → Connect to Wi-Fi → Bind to Mobile App → Run Calibration → Finish Setup

# Bind the Printer



## Note

Before binding, the printer must be connected to a network. If you skipped binding during the initial Setup Wizard, follow the steps below.

1. Tap [⚙️] - [Network] - [Network Settings], turn on the Wi-Fi switch, and select the desired wireless network to connect.

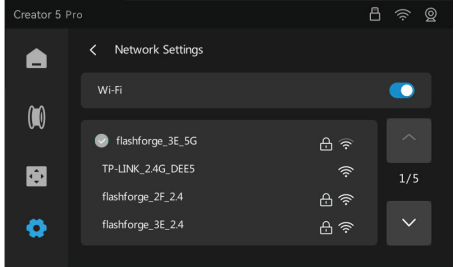
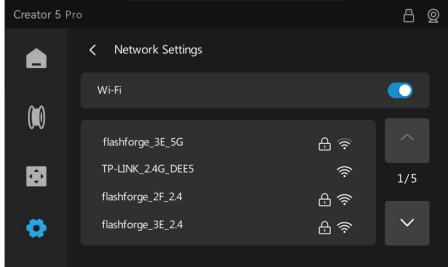
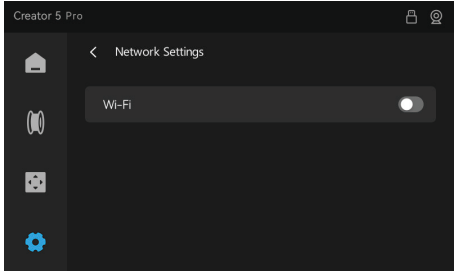
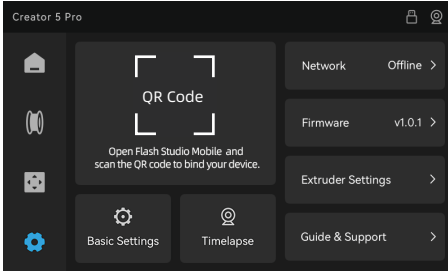

2. Download Flash Studio Mobile by scanning the QR code (see right) or from the app store, register your Flashforge account, and log in.



3. Tap [⚙️] to enter the Settings interface. Use Flash Studio Mobile to scan the QR code on the printer screen to bind the printer to your account.

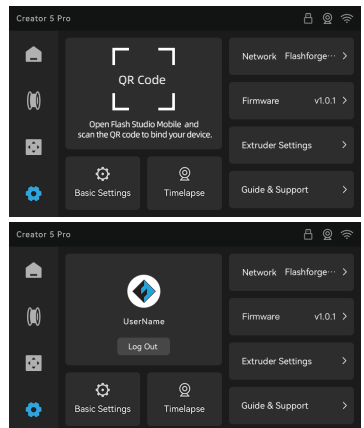
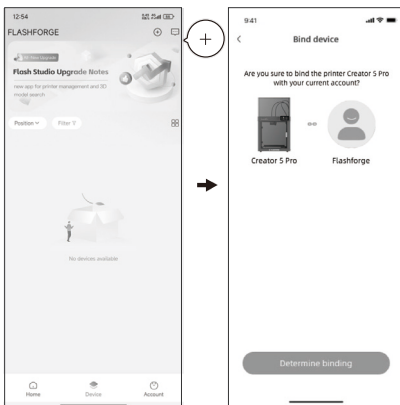

# Install the Slicing Software

Before printing, 3D models must be sliced using presets that match your printer.



Flash Studio

Recommended Slicing Software: Flash Studio Desktop

Download Link: <https://www.flashforge.com/pages/download-center>

## First Print

Note: Each 3D printer undergoes printing tests before leaving the factory. Filament residue on the nozzle is normal.

### Note

When loading filament, please hang each spool as shown.

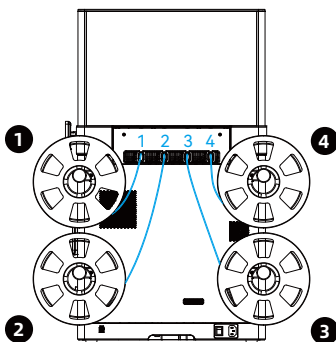

1. Cut off the bent end of the filament. Insert the filament into the filament inlet while pressing down on the extruder lever as shown. Continue feeding the filament until it is fully inserted into the extruder and can no longer be pushed further, and then release the lever.

Cut at a 45° angle

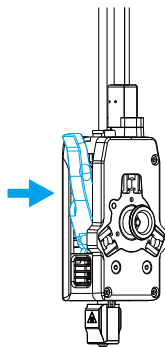
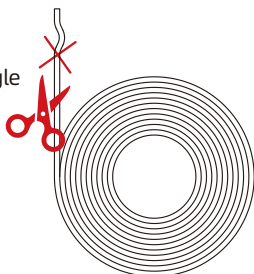

2. Gently pull the filament back. If it cannot be pulled out, the filament has been locked by the extruder feed roller and pre-loading is completed.

3. Tap [  ] to enter the Filament interface. Select the extruder that matches your inlet number (1-4), and then tap [Edit] to set the filament type and color. Repeat this step to configure other filament channels as needed.

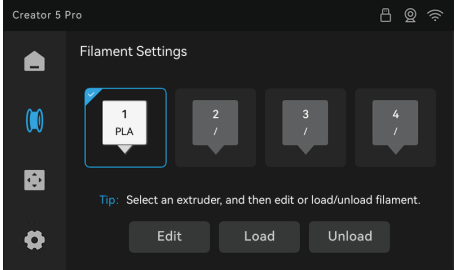
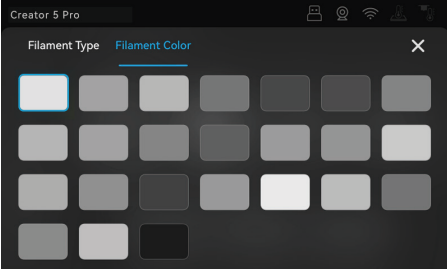
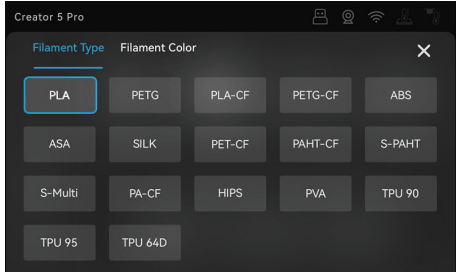
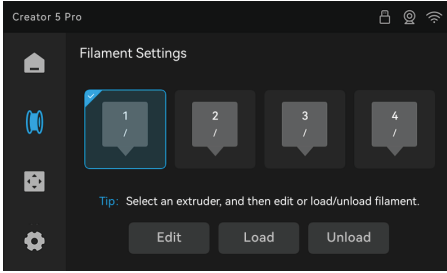

\*Unconfigured extruders appear with a grey background.  
 A "/" indicates no filament detected.  
 A "?" indicates filament is loaded but filament type not configured.

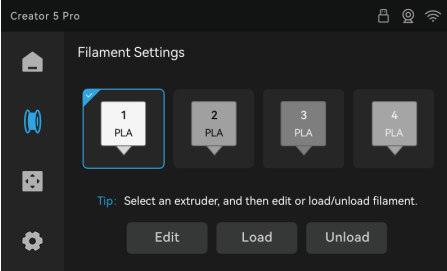

4. Tap [Load] and observe the selected extruder. Filament coming out of the nozzle indicates successful loading.

5. Tap [  ] - [Print File] to start your print job.

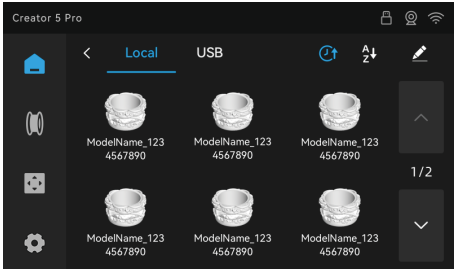
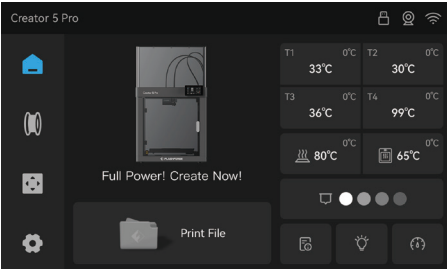

# Technical Specifications

Device Name		Creator 5 Pro
Power Supply	Input	100~120V/200~240V AC, 50/60Hz 1200W
Dimensions	Package Dimensions	520×498×540mm
	Device Dimensions	520×425×722 mm (with spool holders and enclosure) 442×413×722 mm (without spool holders, with enclosure)
	Build Volume	256×256×256mm
Body	Material	Aluminum, steel, plastic
Extruder	Extruder Quantity	4
	Extruder Temperature	Max 320°C
	Nozzle Diameter	0.4mm (default); 0.25/0.6/0.8mm (optional)
	Material	Hardened steel
	Supported Filament Diameter	1.75mm
Print Bed	Max Flow Rate	32mm <sup>3</sup> /s
	Removable Build Plate	PEI-coated steel sheet
	Bed Temperature	Max 120°C
Speed	Max Travel Speed	600mm/s
	Max Print Speed	300mm/s
	Max Acceleration	30000mm/s <sup>2</sup>
Filament	Recommended	PLA/PETG/TPU 95A/TPU 64D/PLA-CF/ PETG-CF/SILK/PVA/BVOH/S-Multi/ S-PAHT/ABS/ASA/PA-CF/PET-CF/PAHT-CF/ ASA-CF/ASA-GF/ABS-GF/PPA-CF/PPS-CF/ HIPS/TPU 90A (top-mounted)
Feature	Refill Printing	Supported
	Auto Leveling	Supported
	Dynamic Flow Calibration (Auto PA Calibration)	Supported
	Active Chamber Heating	Supported, controllable temperature up to 65°C
	Filament Detection	Supported
	Power Loss Recovery	Supported
	Door Open Detection	Supported (front door, top cover)
	Multi-Device Management	Supported
	Chamber Lighting	Supported
	Air Filtration	HEPA13 filter, activated carbon
	Remote Monitoring	Supported, 1280×720, 30 fps HD camera
	Time-Lapse Video	Supported
	Mobile App Support	Supported
Display Screen	4-inch	
Storage	8G	



Visit our official website for more product information.  
[www.flashforge.com](http://www.flashforge.com) - [Support]

## 感谢您选择FLASHFORGE的产品!

如果您之前使用过我们的产品或熟悉3D打印机的使用，我们仍然建议您仔细阅读此手册，文中的操作说明和注意事项能避免错误的安装和使用。

为了让您能够更好的体验本公司的产品，您还可以从以下方式获取设备相关的操作知识和使用技巧：



扫描二维码查看详细的开箱指南，可帮助您快速上手。  
<https://wiki.flashforge.com/zh/creator-series/creator-5-series/manual/unboxing-your-creator-5p>



软件下载：访问地址下载官方切片软件（Flash Studio Desktop）和手机APP（Flash Studio Mobile）  
<https://www.flashforge.com/pages/download-center>



快速入门：访问Flashforge官方Wiki，查阅更多机器使用和维护教程。  
[wiki.flashforge.com](http://wiki.flashforge.com)

## 产品开箱

1. 打开外包装箱，取出上方固定珍珠棉、《快速启动指南》。

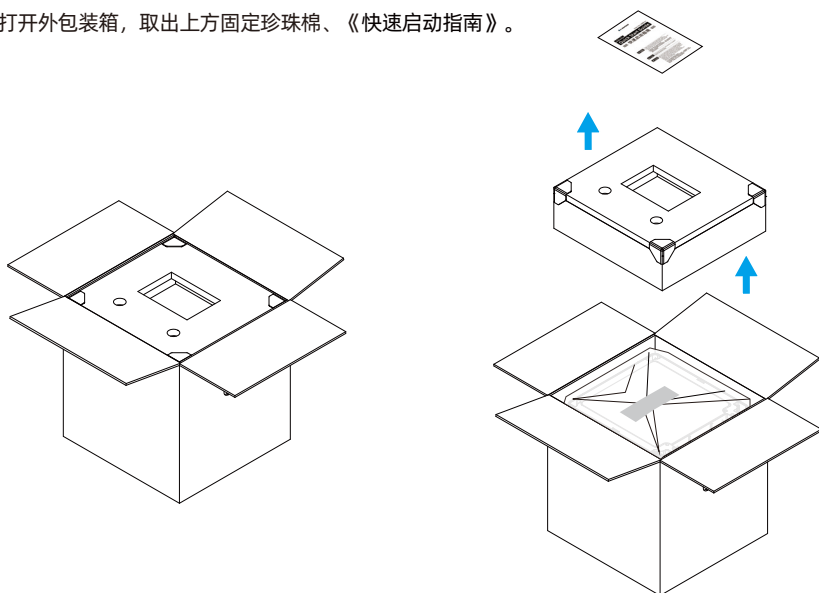

2. 将机器连同包装袋取出，放置水平桌面。

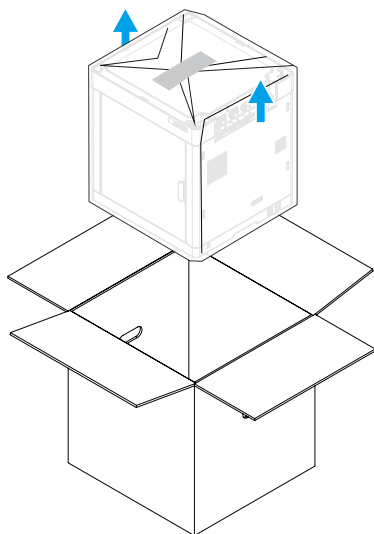

3. 移除包装袋，取出上盖板，并按箭头方向取出腔体内保护棉。

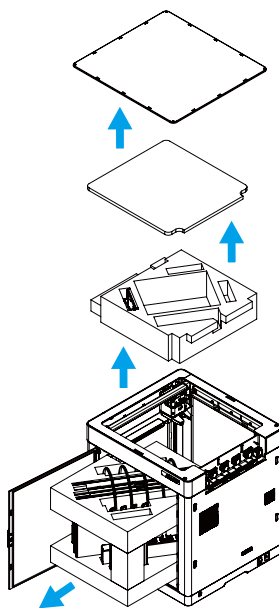

# 配件清单



顶罩上盖

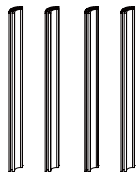

顶罩立柱\*4



顶罩前后板\*2



顶罩左右板\*2

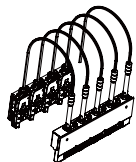

喷头坞模块



3D打印耗材



电源线

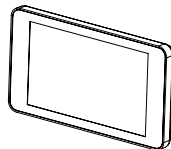

显示屏

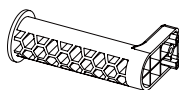

料盘支架\*4

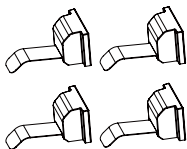

堵嘴片组件\*4

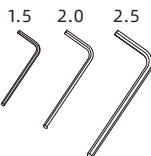

内六角扳手

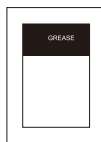

润滑脂

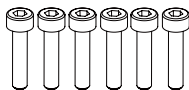

M3×14 \*4  
M3×16 \*2

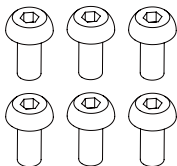

ST2.9×9.5 \*6

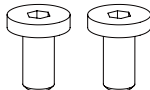

M3×6 \*2



快速启动指南

## 部件介绍

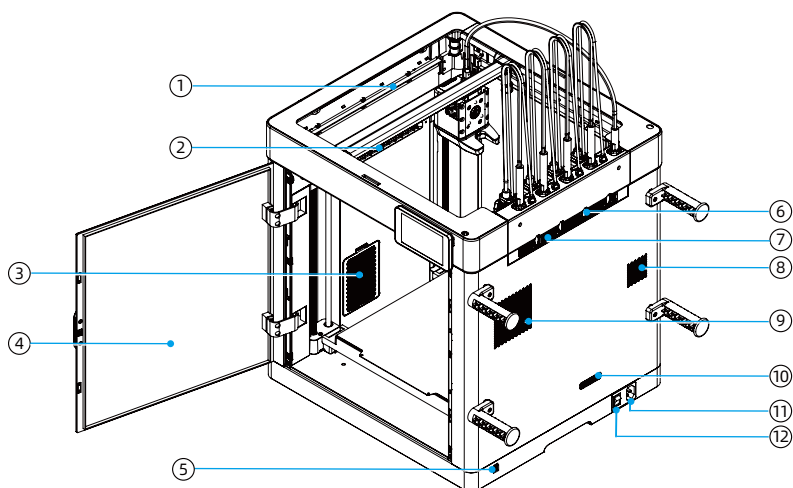

1. 腔体照明灯
2. 辅助冷却出风口
3. 空气滤网
4. 前门
5. 外接通信接口
6. 进料口
7. 喷头散热口
8. 电源散热口
9. 腔体外排风口
10. 主板散热口
11. 电源插座
12. 电源开关

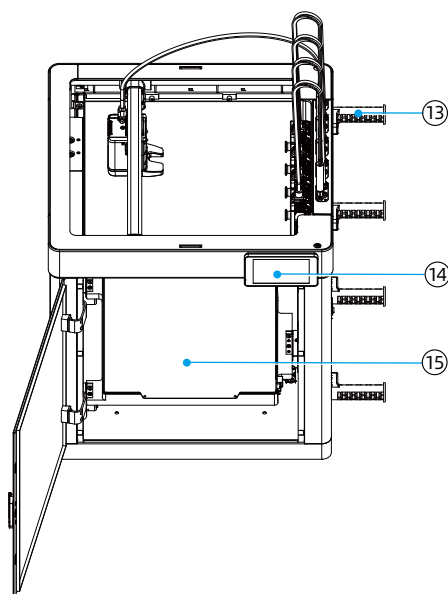

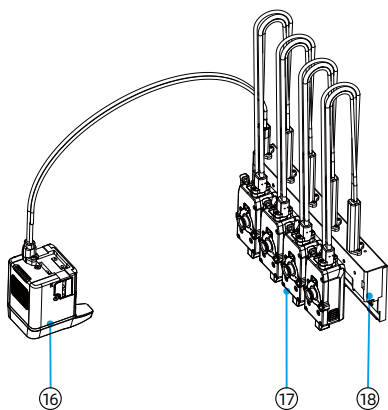

- 16. 喷头座
- 17. 喷头
- 18. 喷头坞

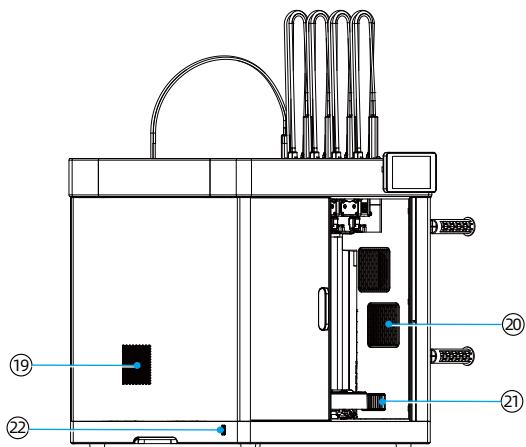

- 19. 腔体冷却进风口
- 20. 腔体加热进风口
- 21. 腔体加热出风口
- 22. USB接口

## 安装屏幕

1. 将显示屏背后的卡槽对准机器上的接口，并按图示安装至打印机。

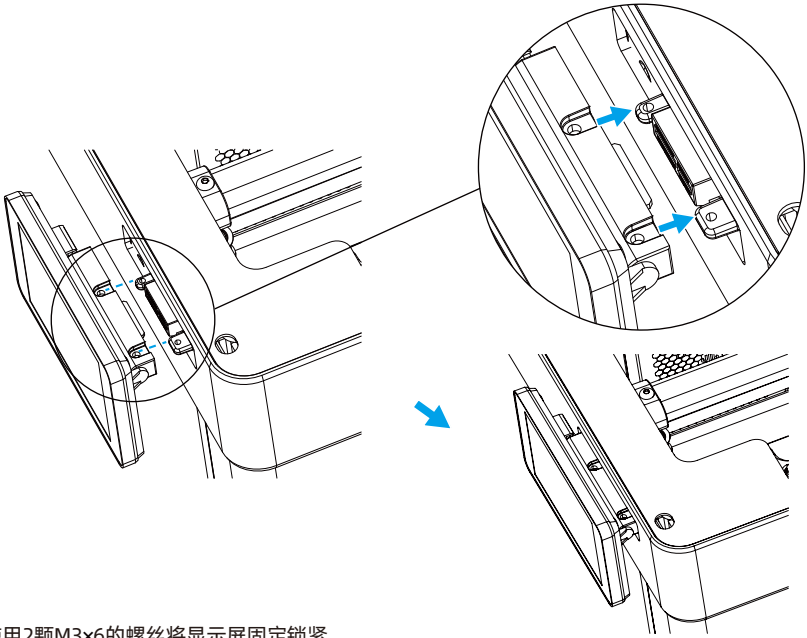

2. 使用2颗M3×6的螺丝将显示屏固定锁紧。

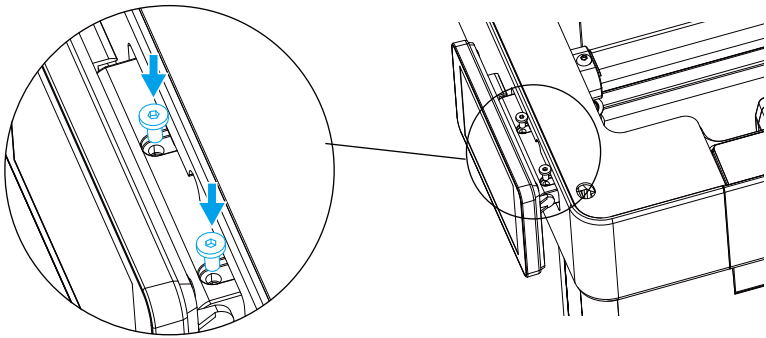

## 安装喷头模块

1. 将4个堵嘴片组件依次插入喷头坞图示卡槽内。

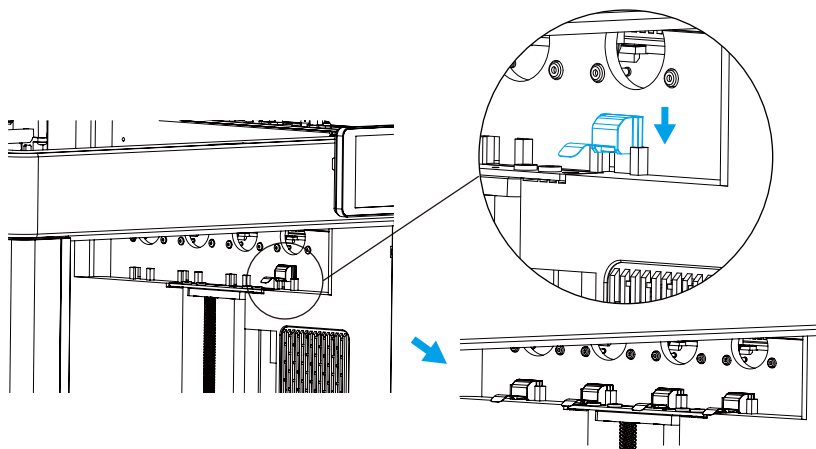

2. 将喷头坞如图位置对准机器右侧卡槽向下插入。

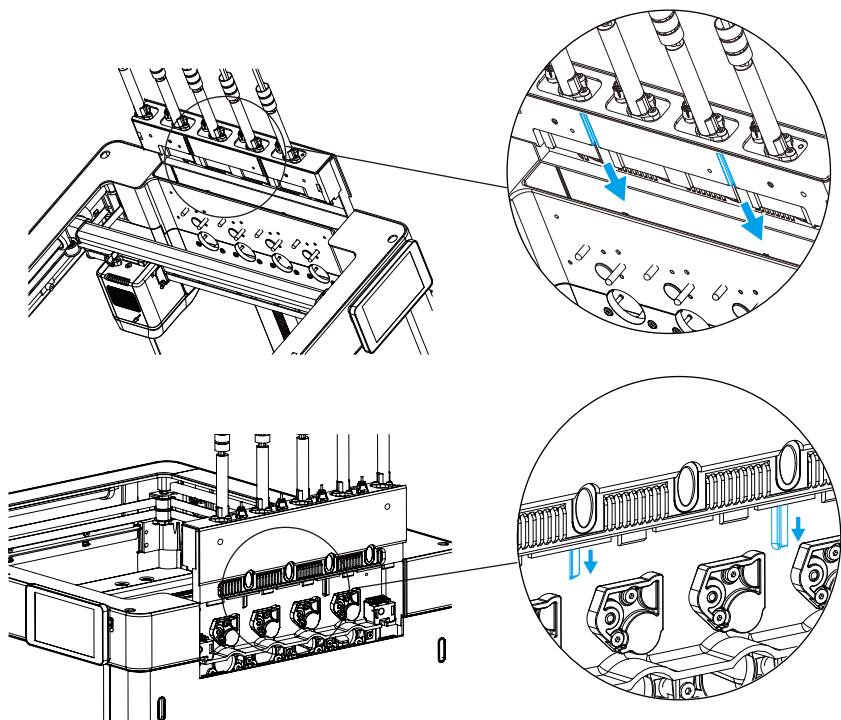

3. 使用2颗M3×16螺丝将喷头坞固定锁紧。

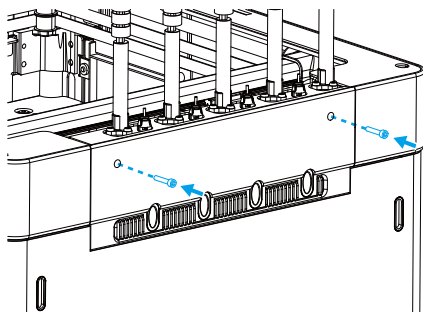

4. 将4个喷头按照对应喷头连接线的顺序，对准定位柱，依次挂载至喷头坞。

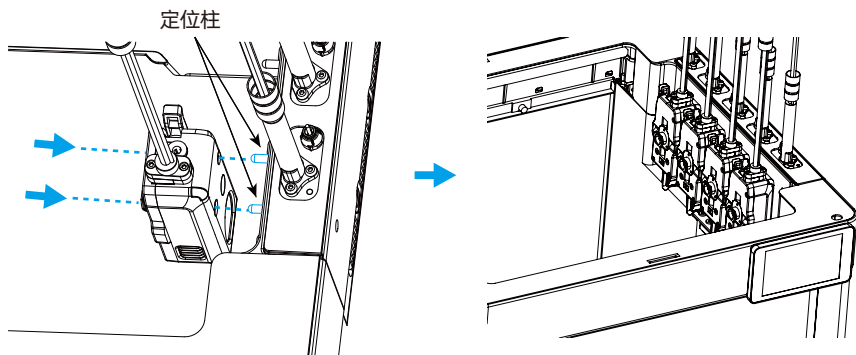

线束连接规范

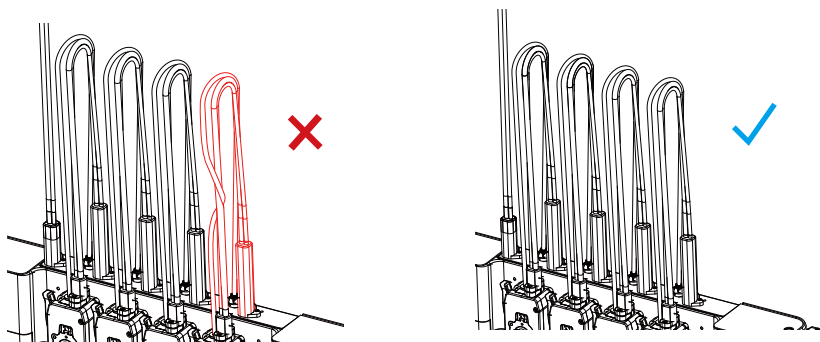

**⚠ 注意事项**

请顺着喷头线束的自然弧度将其理顺，确保喷头线缆与导丝管全程保持平行，避免产生扭曲或“拧麻花”现象。

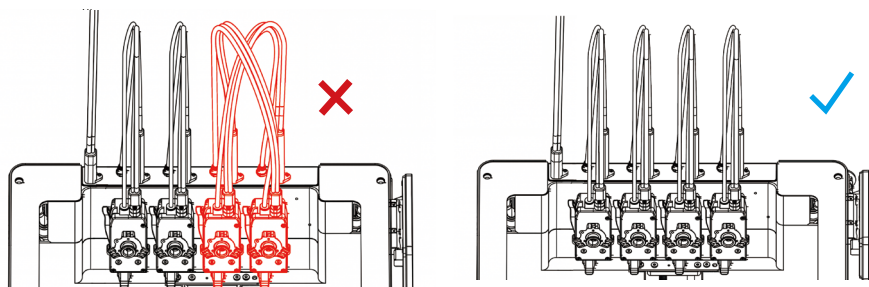

**⚠ 注意事项** 喷头与喷头座需依次一一对应，错误的连接顺序会导致抓取异常，请避免交错连接。

5. 将喷头座连接线插入喷头座上的通信接口，插紧后用两颗ST2.9×9.5螺丝固定锁紧。

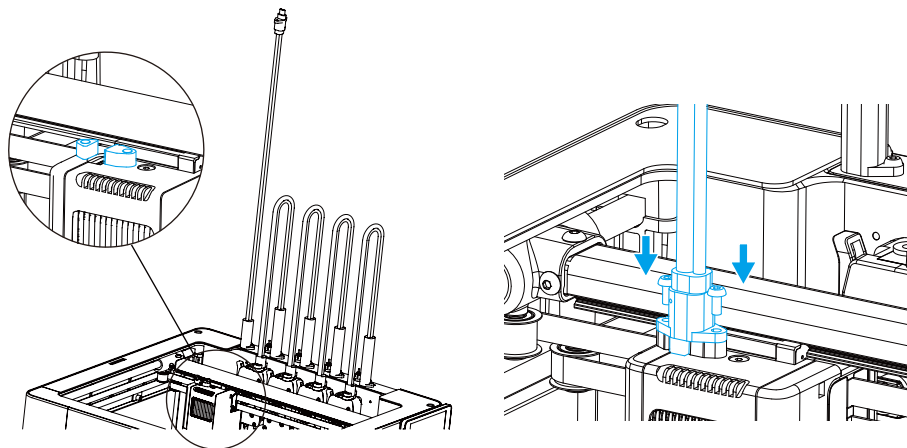

## 解锁打印平台

使用2.5mm内六角扳手拧下箭头标识的3颗平台固定螺丝，解锁打印平台。

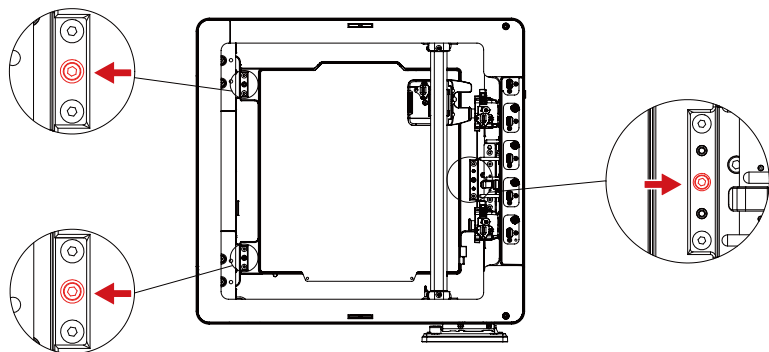

## 安装上罩

1. 将顶罩各面板以图示沿顶罩立柱的凹槽滑入，安装时注意将带有卡扣的一面需统一朝向同侧。

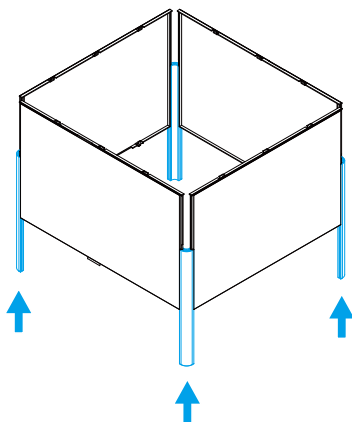

2. 取出顶罩上盖对准卡扣的位置压合，使用4颗ST2.9×9.5的螺丝将上罩顶盖锁紧固定。

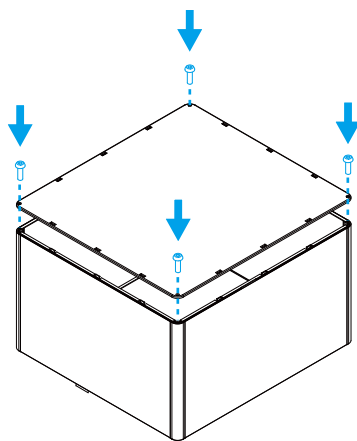

3. 顶罩安装完毕后,如图示将其前后面板上的定位扣对准机器上的孔位,安放至打印机。

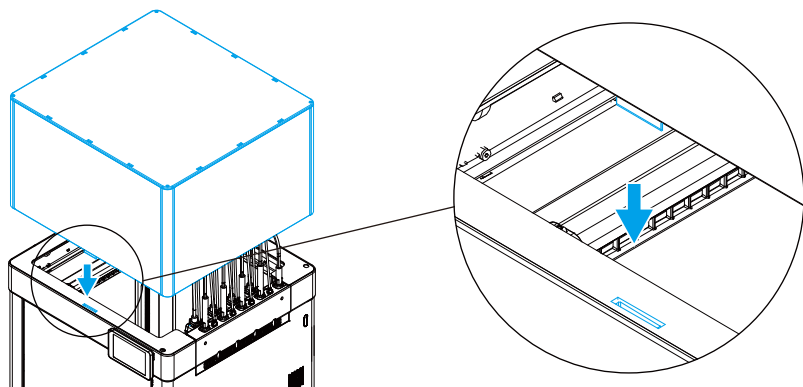

## 安装料架

将料盘支架以图示方向插入机器右侧的4个孔位，使用4颗M3×14螺丝固定锁紧。

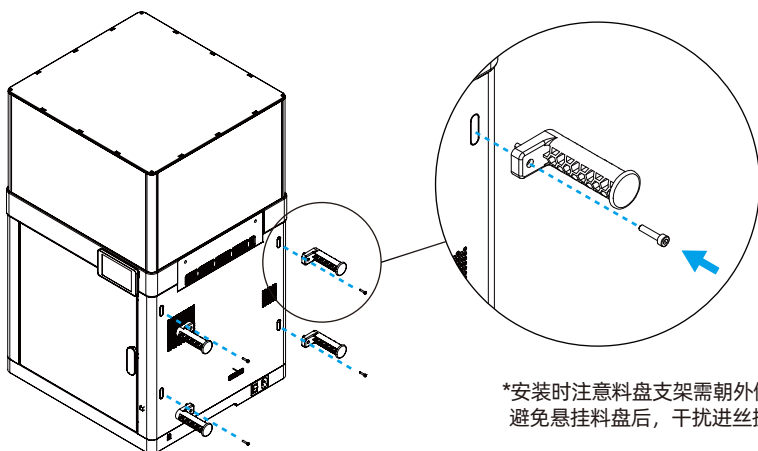

\*安装时注意料盘支架需朝外侧，避免悬挂料盘后，干扰进丝操作。

## 首次开机

**⚠ 注意事项** 开机前请确保完成上述步骤。

1. 接通电源，打开电源开关。

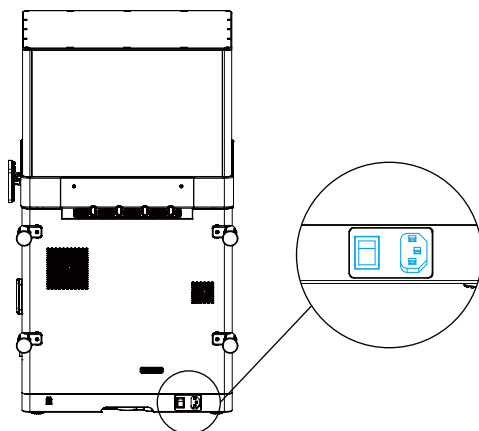

2. 设备首次开机将进入开机引导流程，根据屏幕上的指引完成设备初始化设置。  
选择界面语言→连接Wi-Fi→手机APP绑定打印机→进入校准流程→完成初始化设置。

# 绑定打印机



## 注意事项

绑定打印机前需要先将打印机连接至网络，如果在开机引导流程未绑定打印机，可根据以下步骤进行操作。

1. 点击【】-【网络】-【网络设置】打开Wi-Fi开关，然后选择对应的无线网络进行连接。



2. 扫码(右图)或通过手机应用商城下载Flash Studio Mobile手机应用，注册您的闪铸账号并登录。



3. 点击主页【】进入设备设置界面，用Flash Studio Mobile手机应用扫描打印机屏幕上的二维码，将打印机与您的账号绑定。



## 安装切片软件

三维模型文件打印前需要先进行对应机器的切片预设才能进行打印。



Flash Studio

推荐使用切片软件：Flash Studio Desktop

下载地址：<https://www.flashforge.com/pages/download-center>

## 首次打印

备注：每台设备出厂前均经过打印测试，喷嘴处存在耗材残留属正常现象。

### ⚠ 注意事项

装载耗材时请按图示的对应关系悬挂耗材。

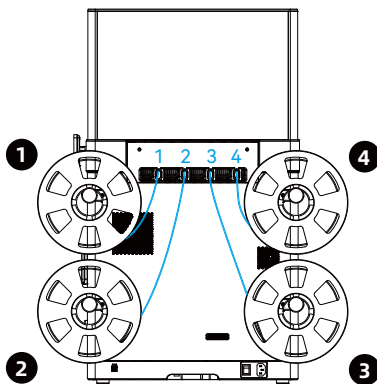

1. 剪去耗材头部弯折部分，将耗材插入进口口，同时按如图示按压喷头把手，并继续推动，直到耗材完全进入喷头，无法继续推动为止后，松开喷头把手。

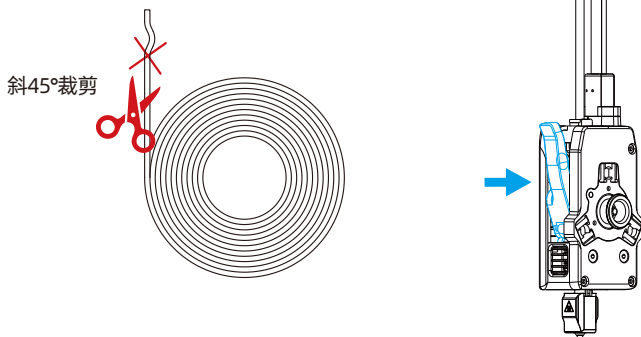

2. 轻轻回拉耗材，如无法拔出，说明已被喷头送丝轮锁住，耗材预装载完成。

3. 在显示屏上点击【】，进入【耗材设置】界面，选中与进料口编号（1-4）对应的喷头位置，点击【编辑】，设置耗材类型与颜色。可重复此步骤设置其他耗材通道。

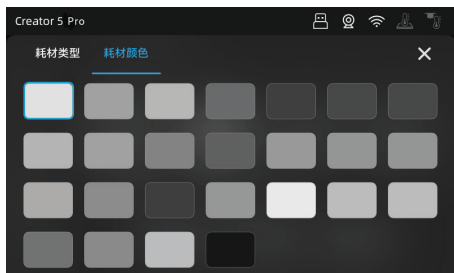
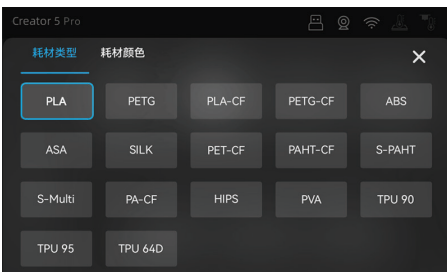

\*未完成设置的喷头，状态显示背景为灰色。  
材料类型显示“/”为未检测到丝料的状态。  
显示“?”为已装载耗材，但未设置耗材类型。

4. 点击【进丝】按钮，观察所选的喷头，当丝料从喷嘴吐出，即进丝成功。

5. 点击【】-【打印文件】，开始您的打印任务。



## 技术参数

设备名称		金刚狼5 Pro
电源	输入	100~120V/200~240V AC 50/60Hz 1200W
	包装尺寸	520×498×540mm
尺寸	机身尺寸	520×425×722mm (带耗材架带封闭罩) 442×413×722mm (不带耗材架, 带封闭罩)
	打印尺寸	256×256×256mm
机身	材质	铝材、钢材、塑料
喷头	喷头数量	4
	喷头温度	最高320°C
	喷嘴口径	0.4mm默认 [0.6/0.8/0.25mm可选]
	材质	硬化钢
	支持耗材尺寸	1.75mm
打印平台	最大喷头流量	32mm <sup>3</sup> /s
	可移除平台配置	PEI涂层钢板
	平台温度	最高120°C
速度	喷头最大移动速度	600mm/s
	最大打印速度	300mm/s
	最大加速度	30000mm/s <sup>2</sup>
耗材	推荐打印	PLA/PETG/TPU 95A/TPU 64D/PLA-CF/ PETG-CF/SILK/PVA/BVOH/S-Multi/ S-PAHT/ABS/ASA/PA-CF/PET-CF/PAHT-CF/ ASA-CF/ASA-GF/ABS-GF/PPA-CF/PPS-CF/ HIPS/TPU 90A(顶部外挂)
功能	续料打印	支持
	自动调平	支持
	动态流量校准 (自动PA校准)	支持
	主动腔体加热	支持, 最高可控温度65°C
	丝料检测	支持
	断电续打	支持
	开门检测	支持 (前门、顶罩)
	多机管理	支持
	腔体照明	支持
	空气过滤	HEPA13 滤网、活性炭
	远程监控	支持, 1280×720; 30 fps 高清摄像头
	延时摄影	支持
	支持APP	支持
显示屏	4英寸	
机身内存	8G	



更多产品相关资料您可以登陆内铸官网查看。  
www.sz3dp.com - [技术支持]

# After-sales Service

## ≡ 售后服务卡 ≡

Zhejiang Flashforge 3D Technology Co., Ltd.



Service: support@flashforge.com  
Suggestions and Complaints: mkt2@flashforge.com



Web: flashforge.com | enterprise.flashforge.com



Address: Floors 2-4, Building B, Huaxing Development Building, No.328 Wen'er Road, Xihu District, Hangzhou City, Zhejiang Province, China

### 浙江闪铸集团有限公司



服务热线: 400 8866 023



建议与投诉: mkt2@flashforge.com



网址: www.sz3dp.com



地址: 浙江省杭州市西湖区文二路328号华星发展大厦B座2-4楼



**Note** The one who sells you the printer should be responsible for your after-sales service.

1. Flashforge grants all end-users a 12-month limited warranty for all Flashforge 3D printers (except the Flashforge extruder) and a 3-month warranty for Flashforge FFF Extruder.
2. If Flashforge 3D printer fails during normal and proper use within the warranty period (judged by Flashforge engineers), Flashforge will provide users with free maintenance services or remote after-sales support.
3. The warranty period starts from the outbound date, or starts from the invoice date if clear and confirmed invoice is provided.
4. Flashforge will repair or replace only the defective parts with new or reconditioned parts or products that are functionally equivalent or superior to those originally supplied. If a part is repaired or replaced during the warranty period, the warranty period still remaining for the entire printer will apply to this part.



**注意事项**

闪铸科技采用谁销售谁服务的原则，如您的3D打印机是在非闪铸官方平台购买，请向您购买的商家获取相关支持

1. 闪铸科技所有3D打印机均为用户提供12个月整机有限质保。其中FFF技术3D打印机的喷头质保时间为3个月。
2. 质保期内若设备出现非人为损坏（由闪铸工程师评定），您将获得免费配件及售后技术支持。
3. 售后服务周期以产品出厂日期为起始。如能提供清晰的发票，则以发票开具日期为起始。
4. 维修零配件可能为非全新配件，但甲方保证配件功能完全正常。维修配件质保时间与其整机质保时间相同。

## Parts Excluded from This Warranty

Build Tape / Build Plate / Acrylic Cover / SD Card / USB Stick / USB Cable / Filament / Filament Spool / Glue / Resin Vat / Film / Rinse Bucket / Gloves / Plastic Scraper / Metal Scraper / Brush / Allen Wrench (2.5mm\*1/3mm\*1/5mm\*1) / Stamping Wrench / Tools Bag / Accessories

\*FFF extruder kit shall be purchased independently due to upgrading.

## WHAT IS NOT COVERED

- ◆ Unable to provide valid After-sales Service Card or Serial No. (Including but not limited to lost, alter or fuzzy cannot be confirmed);
- ◆ FFF commercial printers out of warranty period or over 1000 working hours; FFF consumer printers out of warranty period or over 400 working hours;
- ◆ Damage(s) caused by improperly or incorrectly performed modifications, alterations or repair;
- ◆ Damage(s) due to operation under improper environment (damp, wet or other extreme weather);
- ◆ Exterior scratch or flaw caused by abrasion, aging or normal use;
- ◆ The warranty period of printer or part has expired;
- ◆ Damage(s) caused in service shops unauthorized by Flashforge;
- ◆ Damage(s) caused by improperly installation, use or operation;
- ◆ Damage(s) caused by abuse (overloaded working), misuses;
- ◆ Damage(s) caused by using unauthorized spare parts or poor quality filament (Recommended to use Flashforge filament);
- ◆ Damage(s) caused by using third-party software;
- ◆ Damage(s) caused by force majeure (such as a lightning strike, fire, earthquake, floods or any other event beyond human control);
- ◆ Damage(s) caused by using third-party parts.



## After-sales Service Registration Form

Series No.: \_\_\_\_\_ Purchase from: \_\_\_\_\_

Fault Description: \_\_\_\_\_

\_\_\_\_\_

Tel.: \_\_\_\_\_ Contact: \_\_\_\_\_

Add.: \_\_\_\_\_

- ❗ Please fill in this form carefully, cut out this form and mail it back to Flashforge together with the printer, or download this form from [www.flashforge.com](http://www.flashforge.com), fill in this form and send it to [support@flashforge.com](mailto:support@flashforge.com). After-sales service shall not be provided without this form.
- ❗ Please contact your printer's reseller to get After-sales service help if your printer is not purchased on official Flashforge website.

## 以下配件不列入质保范围

平台贴纸 / 平台金属板 / 平台玻璃板 / 亚克力罩 / SD卡及U盘 / USB线 / 打印耗材 / 丝盘轴 / 溶液盒 / 薄膜 / 打印平台 / 遮光罩清洗盒 / 塑料铲刀 / 金属铲刀 / 刷子 / 清洗手套 / 内六角扳手(2.5mm\*1/3mm\*1/5mm\*1) / 开口扳手 / 工具包及包内工具。

\*由于FFF产品喷头会有迭代升级，喷头升级套件需单独购买。

## 以下情况不在质保范围内

- ◆ 无法提供有效质保卡或序列号(遗失、涂改、模糊无法确认);
- ◆ 整机及部件已经超过质保有效期;
- ◆ FFF商用设备运行总时长超过1000小时, FFF消费级设备运行总时长超过400小时;
- ◆ 设备曾经在未经闪铸授权的维修店维修;
- ◆ 设备在非产品规定的工作环境下使用而造成的设备故障或损坏;
- ◆ 设备正常磨损、老化或因操作造成的外观划痕或瑕疵;
- ◆ 由于使用非闪铸指定的软件而造成的设备故障或损坏;
- ◆ 由于使用其它品牌部件造成的设备故障或损坏;
- ◆ 由于私自对设备进行改装而造成的设备故障或损坏;
- ◆ 由于错误安装、使用而造成的设备故障或损坏;
- ◆ 由于滥用(包括超出工作负荷)、误用而造成设备故障或损坏;
- ◆ 由于使用低质量耗材而造成的设备故障或损坏(建议使用闪铸官方耗材);
- ◆ 由于维护不当(受潮、发霉或暴露在极端气候)造成的设备故障或损坏;
- ◆ 由不可抗因素(如火灾、地震、雷击、水灾等)造成的故障或损坏。



## 售后服务登记表

序列号: \_\_\_\_\_ 从何处购买: \_\_\_\_\_

故障描述: \_\_\_\_\_

\_\_\_\_\_

联系电话: \_\_\_\_\_ 联系人: \_\_\_\_\_

地址: \_\_\_\_\_

❗ 请务必仔细填写此表, 剪下并随机器寄回闪铸科技, 或在闪铸官网(官网地址见反面)下载此表发送给[support@flashforge.com](mailto:support@flashforge.com)。  
未填写此表将无法进行售后服务。

❗ 如您非闪铸官方平台购买机器, 请直接联系您购买的商家获取售后支持。









Follow us

## **Zhejiang Flashforge 3D Technology Co., Ltd.**

Address: Floors 2-4, Building B, Huaxing Development Building,  
No.328 Wen'er Road, Xihu District, Hangzhou City, Zhejiang Province, China

Service: [support@flashforge.com](mailto:support@flashforge.com)

Suggestions and Complaints: [mkt2@flashforge.com](mailto:mkt2@flashforge.com)

Web: [flashforge.com](http://flashforge.com) | [enterprise.flashforge.com](http://enterprise.flashforge.com)

## **浙江闪铸集团有限公司**

地址：浙江省杭州市西湖区文二路328号华星发展大厦B座2-4楼

服务热线：400 8866 023

建议与投诉：[mkt2@flashforge.com](mailto:mkt2@flashforge.com)

网址：[www.sz3dp.com](http://www.sz3dp.com)