

Quick Start Guide

≡ 快速启动指南 ≡

中文P16

**⚠ WARNING
注意事项**

1. Please refer to this Guide for initial printer setup.
2. Hot! Avoid touching the heating nozzle in operation.
3. Moving parts in the printer may cause injuries. Do not wear gloves or other sources of entanglement in operation.

1. 请参照本指南完成打印机的初始准备。
2. 高温危险！打印机喷嘴在工作时会被加热，操作时请避免接触！
3. 可动部件可能会造成卷入挤压和切割伤害。操作机器时请不要佩戴手套或缠绕物。

**⚠ Safety Notice
安全提示**

Do not power on the printer until installation is completed.
请勿在打印机安装完成之前通电。

**⚠ LEGAL STATEMENT
法律申明**

Users are not authorized to make any modifications to this Quick Start Guide.
Flashforge shall not be held responsible for any safety incidents resulting from the disassembly or modification of the equipment by the customer. No one is allowed to modify or translate this Guide without Flashforge's permission. This Guide is protected by copyright, and Flashforge reserves the right of the final interpretation of this Guide.

用户无权对此使用手册进行任何修改。
客户若自行拆装或改造设备造成任何安全事故，闪铸集团概不负责。未经闪铸集团允许，任何人不得对该手册进行修改或翻译。
本手册受版权保护，闪铸集团对本手册保留最终解释权。

Unboxing Instructions

1. Open the box.

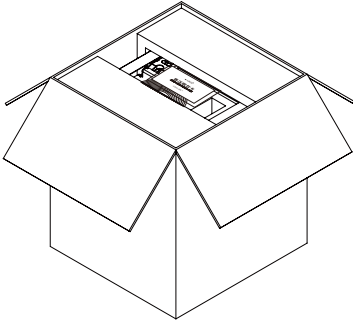

2. Remove the upper foam packaging, Quick Start Guide and After-sales Service Card.

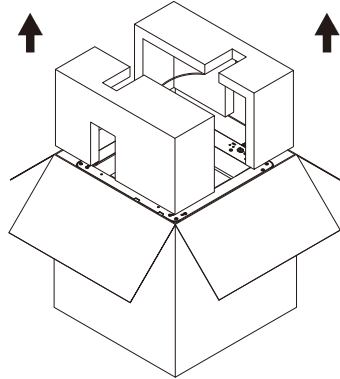

3. Take out the machine, place it on a level workspace and remove the packaging bags and tapes.

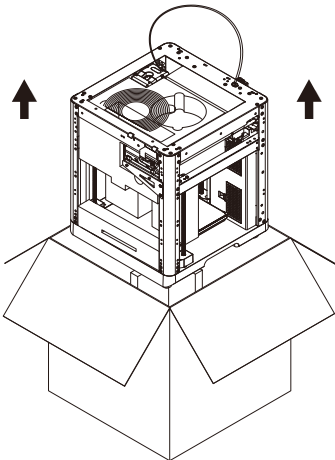

4. Remove the filament, power cable, and accessory kit from the chamber protective foam.

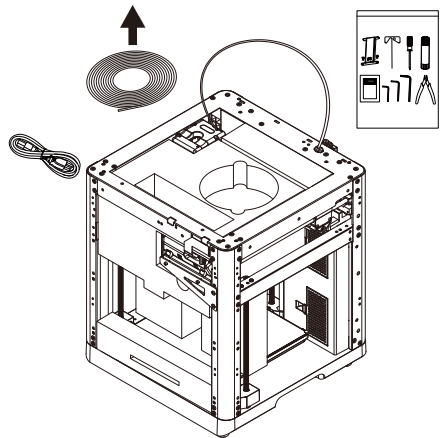

5. Remove the screws and sheet metal following the arrow direction. Flip the display screen, and push it in the direction of the arrow to lock it in place.

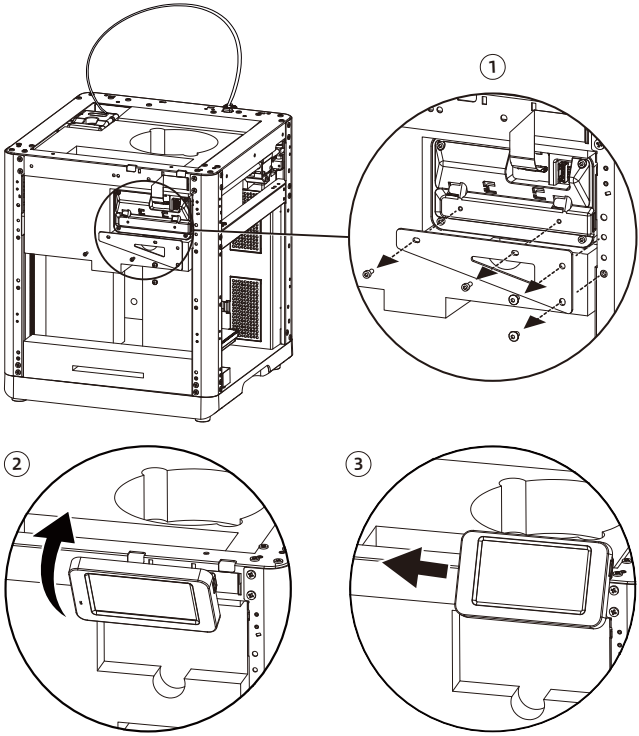

6. Remove the foam around the extruder and the build plate.

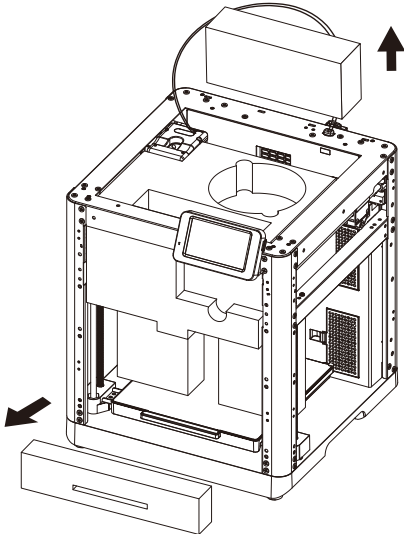

7. Move the chamber foam according to the arrow direction.

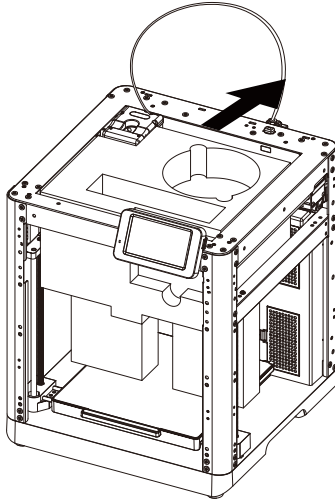

8. Remove the foam to complete the unboxing.

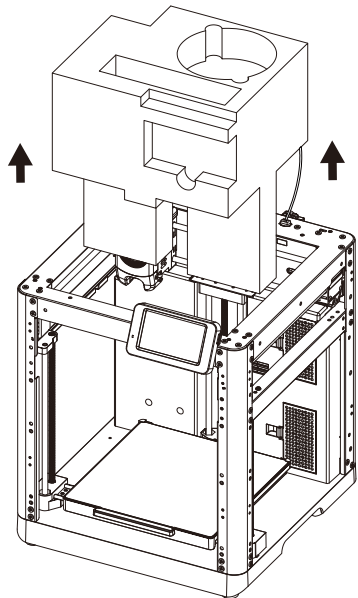

Packing List

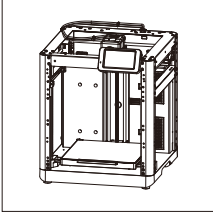

3D Printer

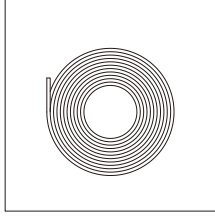

Filament

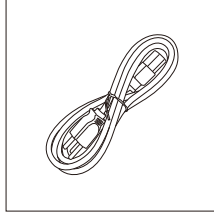

Power Cable

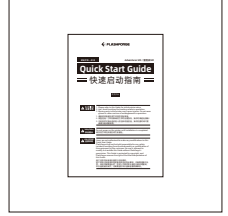

Quick Start Guide

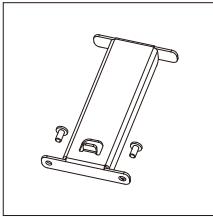

Spool Holder
(with 2 screws)

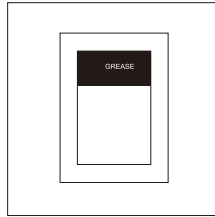

Grease

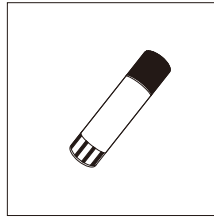

Glue

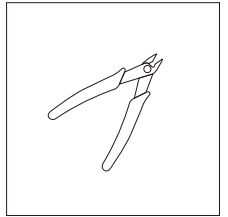

Diagonal Pliers

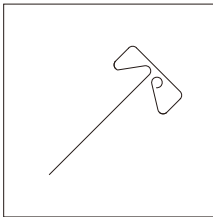

Unclogging Pin Tool

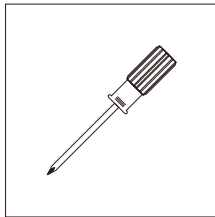

Screwdriver

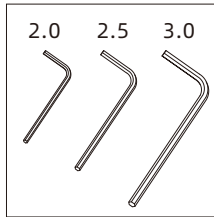

Allen Wrench

Printer Components

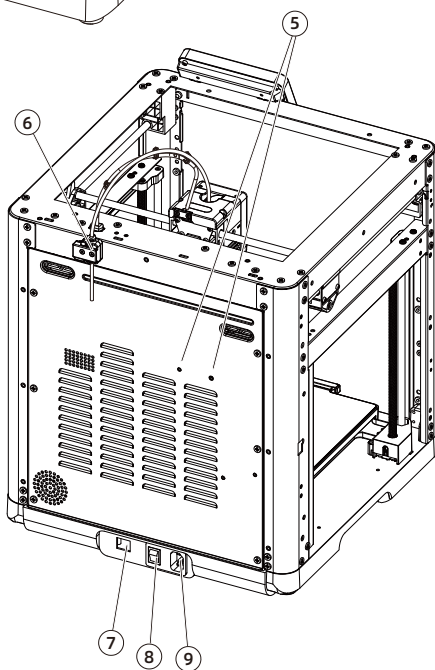
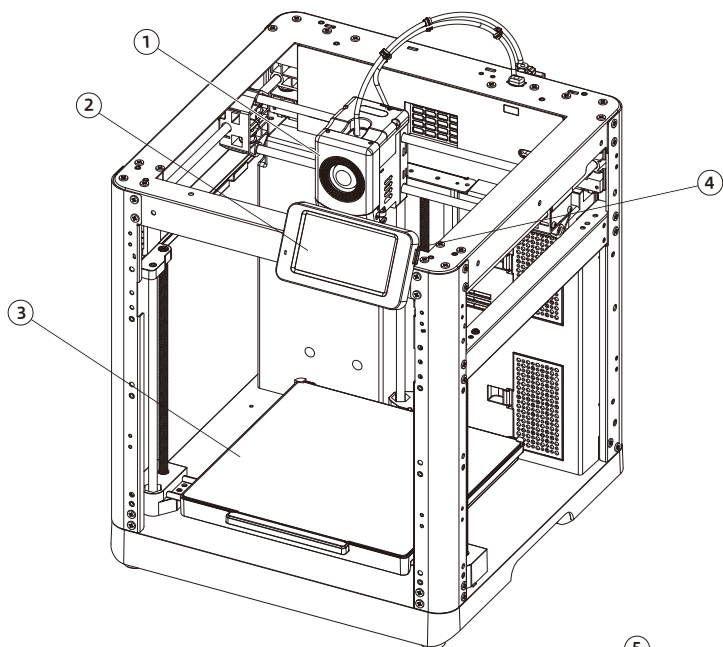

1. Extruder
2. Touch Screen
3. Build Plate
4. USB Port
5. Screw Holes for Spool Holder
6. Filament Detection Sensor
7. Ethernet Input
8. Power Switch
9. Power Socket

Install the Spool Holder and Filament Guide Tube

1. Take out the two screws and spool holder from the accessory box.

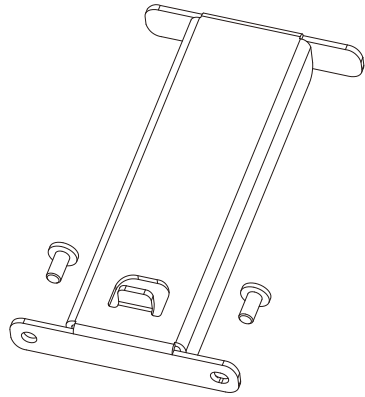

2. Install the spool holder at the position shown in the figure with the two screws. (Note: Please tighten them using a 2.0mm Allen wrench.)

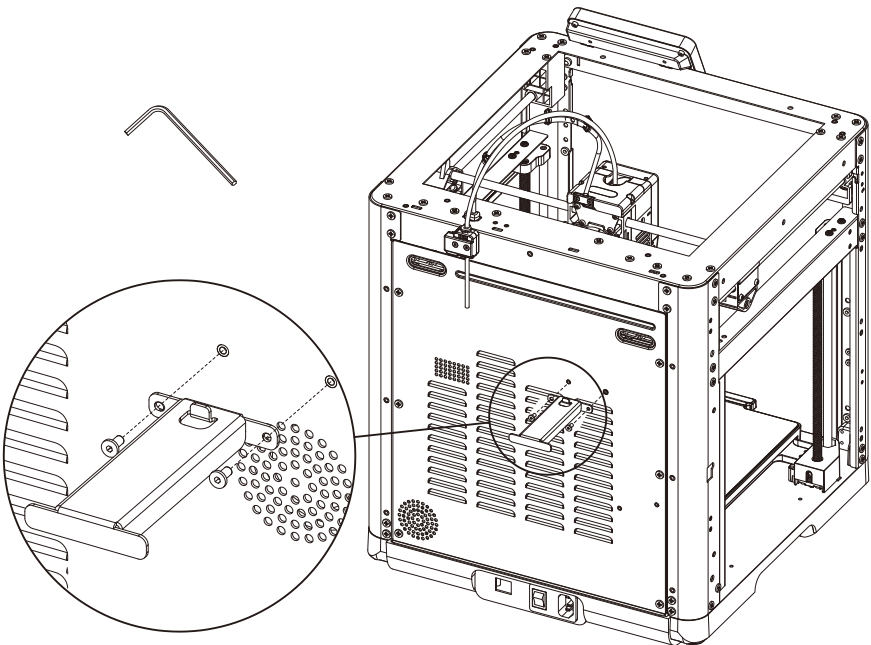

3. Insert the filament guide tube to the extruder.

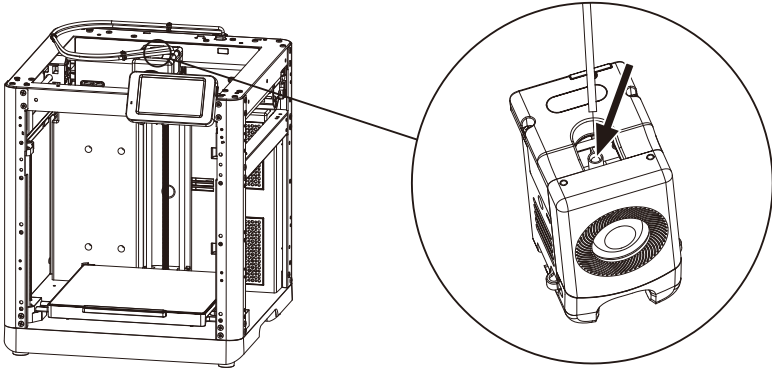

4. Insert the other end of the filament guide tube into the filament detection sensor.

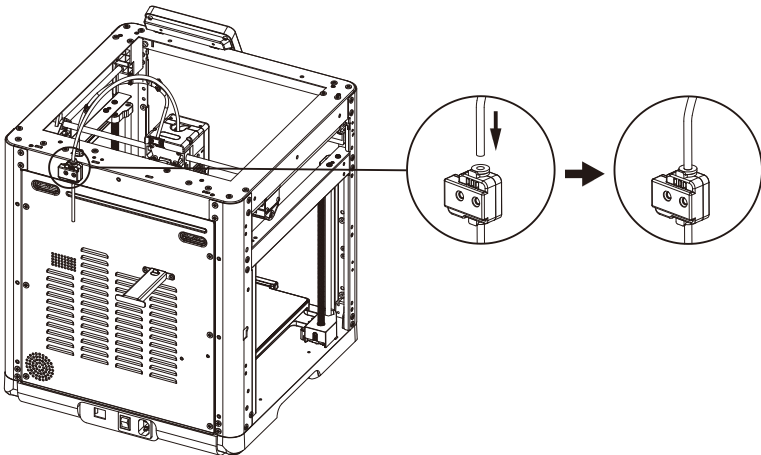

Unlock the Build Plate

⚠ Note Please ensure the platform has been cleared up.

Please use a 2.5mm Allen wrench to remove four screws which lock the build plate (as indicated by the arrow).

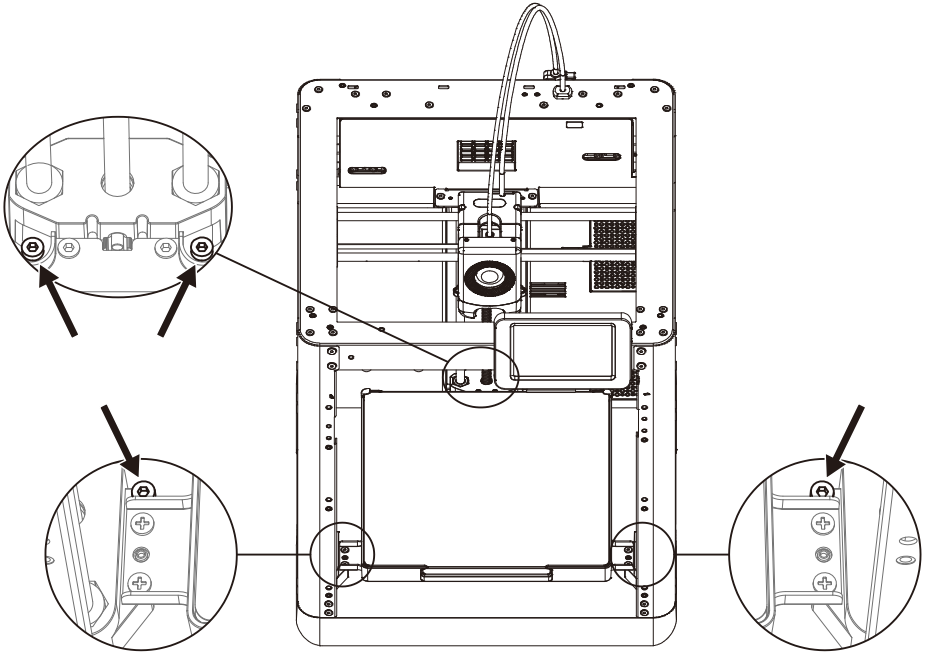

First Print

* The interface layout may change whenever there is an upgrade of firmware.

1. Power on the printer, turn on the power switch, and wait for the screen to respond.

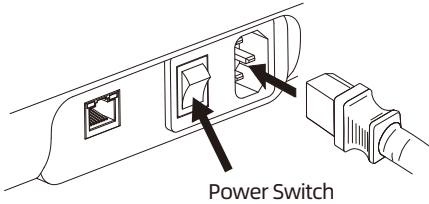

2. Following the guide on the screen, select the language.



3. Turn on the Wi-Fi switch and connect to the network following the instructions. A successful connection notification will pop up once connected.

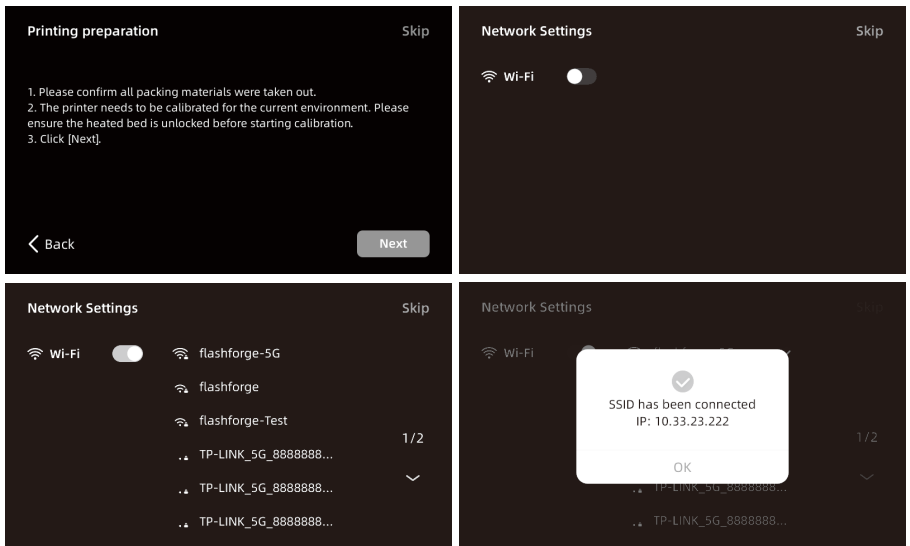

4. Bind the printer following the instructions. (Note: If skipped, binding can still be done later on the printer, see User Guide for details.)

a. After clicking [OK], the QR code page will appear.

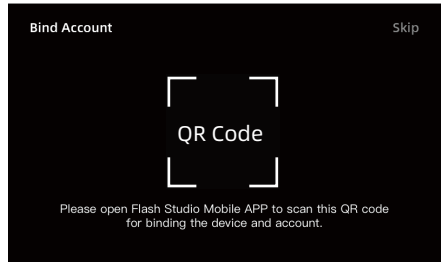

b. Download Flash Studio Mobile by scanning the QR code (see right) or from the app store, register your Flashforge account, and log in.



c. Use Flash Studio Mobile to scan the QR code on the printer screen to bind the printer to your account. (Note: Default printer name and location are set upon leaving the factory; after completing the startup, you can customize the printer name and location in the settings.)

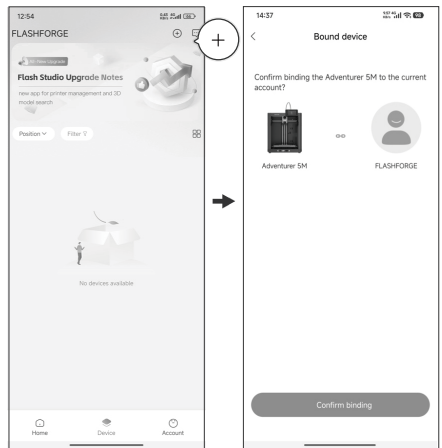

5. Click [Next] and the machine will perform the first calibration. Vibrations and noise during calibration are normal. (Note: Please keep the machine on a stable surface and do not move it during calibration.)

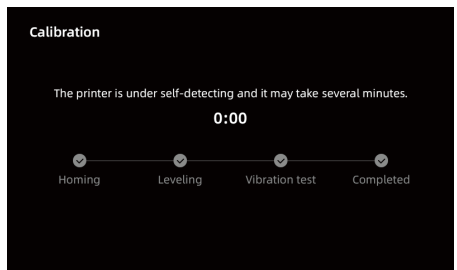
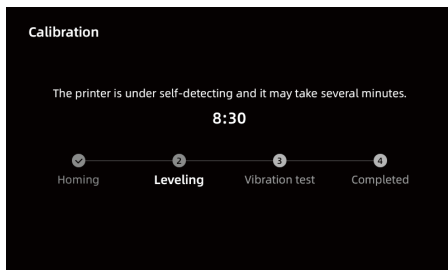

6. Load filament following the on-screen startup boot:

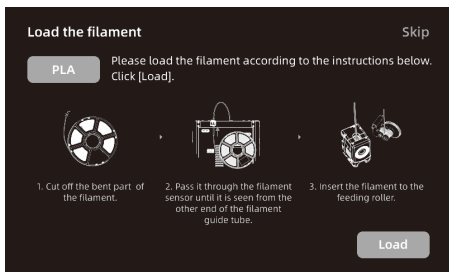

a. Cut off the bent part of the filament end.

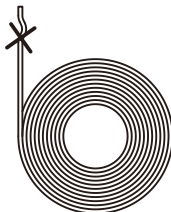

b. Hang the bent filament on the spool holder. Pass it through the filament sensor until it's seen from the other end of the filament guide tube. Push it forward to the feed roller, until it can not go further. (Please use PLA filament for the first print on initial setup).

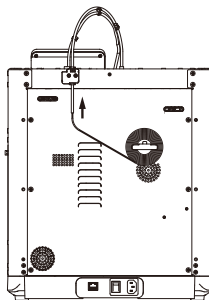
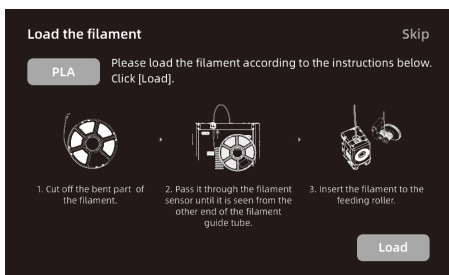

C1. Click [Load] and select [PLA] for the first print. C2. Wait for the extruder to heat up.

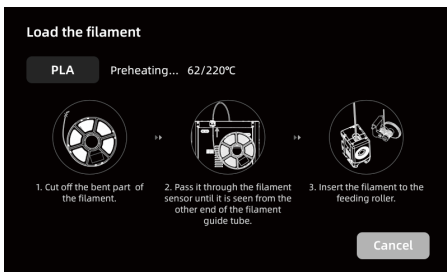
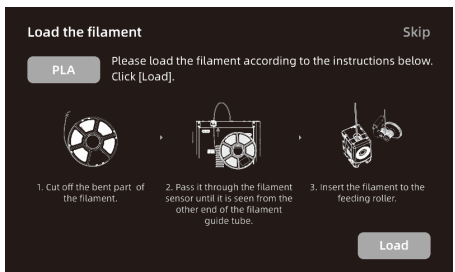

C3. Feeding will begin after heating. Successful filament extrusion from the nozzle indicates successful loading. Lastly, confirm the filament guide tube is properly inserted.

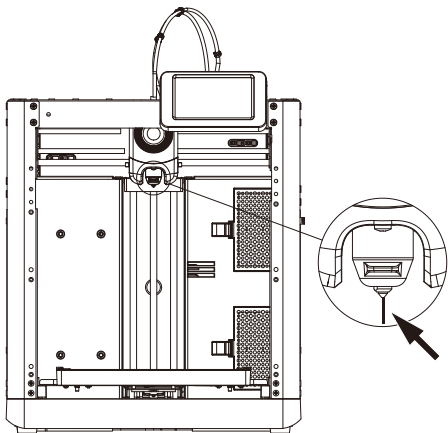
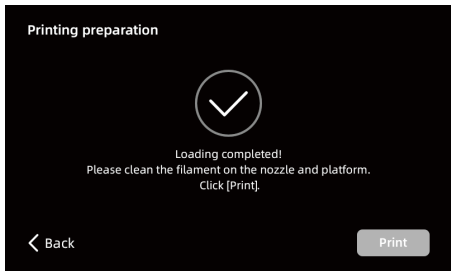
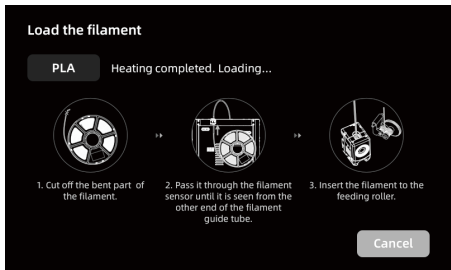

Note

If no filament is extruded, manually insert the filament into the inlet and click [Back] to retry. Feel for filament movement until it is extruded.

7. Please clear the filament residues on the nozzle and platform. Users must apply glue to the platform so as to improve adhesion for the first print.

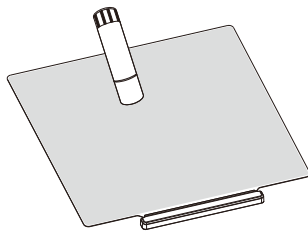

8. Click [Print] and the machine starts printing the built-in file (configured for PLA material).

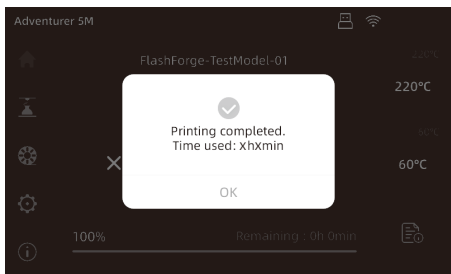

For more information, you can visit the Flashforge official website. www.flashforge.com - [Support]

Flash Studio Desktop Instructions



Flash Studio Desktop

* The steps are illustrated for one machine type.

Flash Studio Desktop is a slicing software developed based on OrcaSlicer, with custom features tailored for the Adventurer 5M series.

Download Instructions:

1. Download the latest slicing software from:
<https://www.flashforge.com/pages/download-center>.

1. Open the installed Flash Studio Desktop.

2. Setup Wizard:

Follow the setup wizard prompts for selecting your region, machine type, and materials.
(Note: You can select all machine types and material types in the list for later slicing options.)

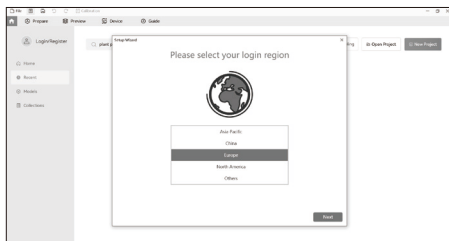

3. Account Login/Register:
 Log in to Flash Studio Desktop using your Flashforge account. If you don't have an account, register one using your mobile phone number. (Note: Flash Studio Mobile and Flash Studio Desktop share the same account.)

4. Create or open a project for slicing. You can select the machine type, material, and recommended parameters in the printer, filament, and process bars.

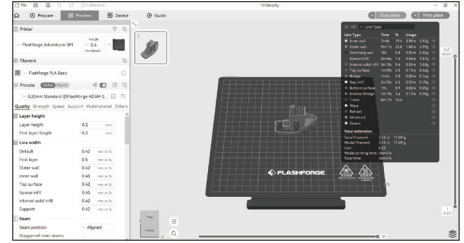
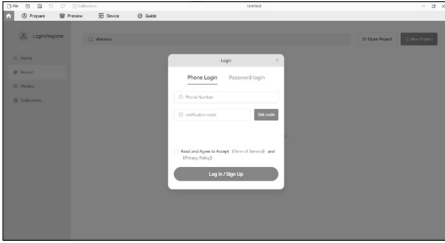

5. After slicing, select the printer and send for printing.

6. You can remotely monitor the printing progress and pause/stop printing when necessary on the device interface. (Note: Real-time monitoring is only available with a camera installed and activated.)

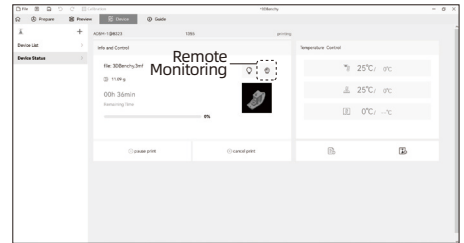
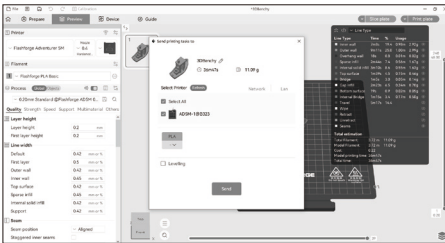

Tip:

For details and tutorials on software usage, please refer to Flashforge Wiki. (<https://wiki.flashforge.com/en/home>).

Parameters

Machine Name	Adventurer 5M
Extruder Quantity	1
Printing Precision	±0.1mm [testing based on 100mm cubes]
Positioning Accuracy	X/Y-axis: 0.0125mm, Z-axis: 0.0025mm
Layer Thickness	0.1-0.4mm
Build Volume	220 x 220 x 220mm
Nozzle Diameter	0.4mm default [0.6/0.8/0.25mm optional]
Printing Speed	10-300mm/s
Max Acceleration	20000mm/s ²
Max Travel Speed	600mm/s
Max Extruder Temperature	280°C
Supported Filament	*PLA/*PETG [0.4mm nozzle] *TPU/PLA-CF/PETG-CF [0.6/0.8mm nozzle] Note: Materials marked with * are recommended for printing.
Power Supply	Input: AC 100~120V/200~240V, 50/60Hz, 350W
Device Size	363 x 376 x 413mm [excluding the display screen and spool holder] 363 x 402 x 448mm [including the display screen, excluding the spool holder]
Net Weight	10.8kg
Connectivity	USB/Wi-Fi/Ethernet
Operating Temperature	15-30°C
Compatible Operating System	Windows 7/8/10/11; Linux: support version Ubuntu 20.04 or later; Mac OS: support version 10.9 or later
Slicing Software	Flash Studio Desktop/OrcaSlicer
Max Platform Temperature	110°C
Leveling Method	One-click auto leveling
Filament Run-out Reminder	√
Power Loss Recovery	√
Smart Touch Screen	4.3-inch
Build Plate	PEI flexible steel plate

产品开箱

1. 打开纸箱。

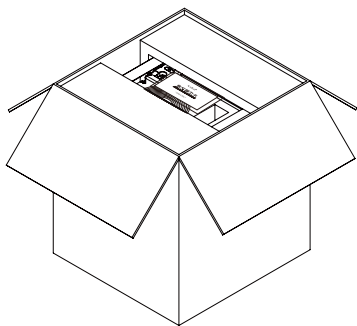

2. 取出上方固定泡棉以及快启售后服务卡。

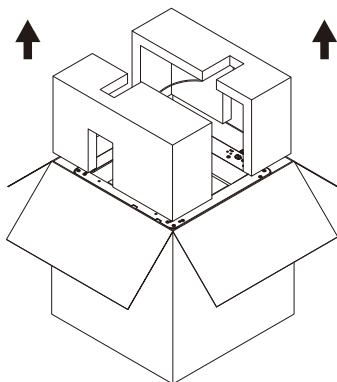

3. 取出机器放置水平桌面，去除包装袋和固定胶带。

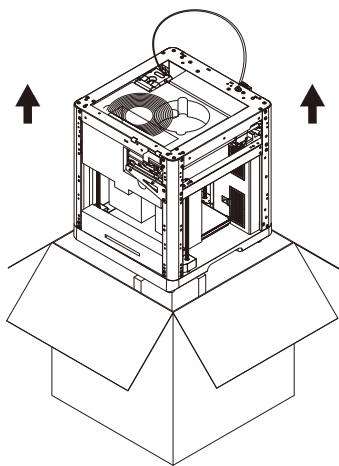

4. 取出腔体保护棉内的耗材、电源线、配件包。

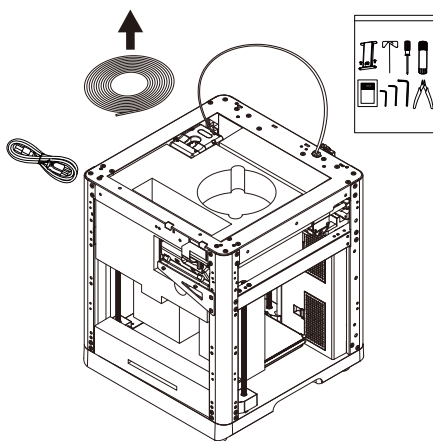

5. 按照箭头方向取下螺钉和钣金，翻转显示屏，按箭头方向推动屏幕将其锁紧。

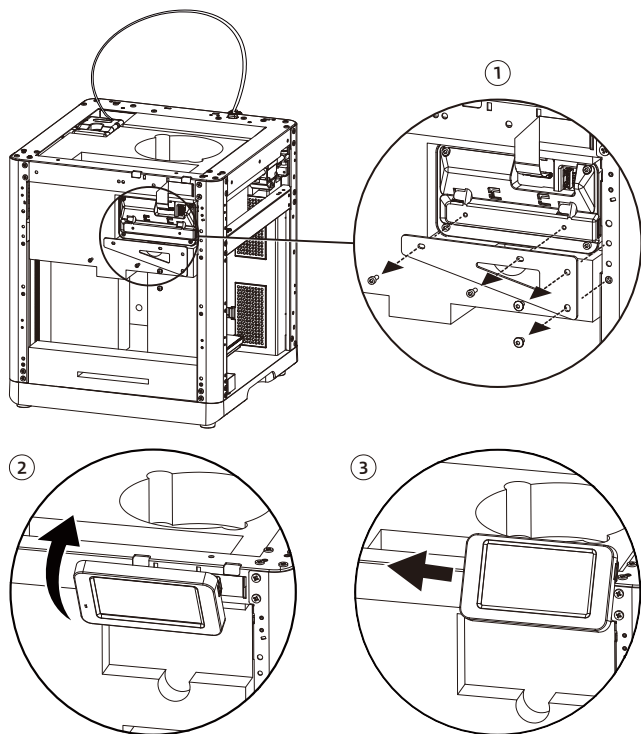

6. 移除喷头内侧保护棉和平台保护棉。

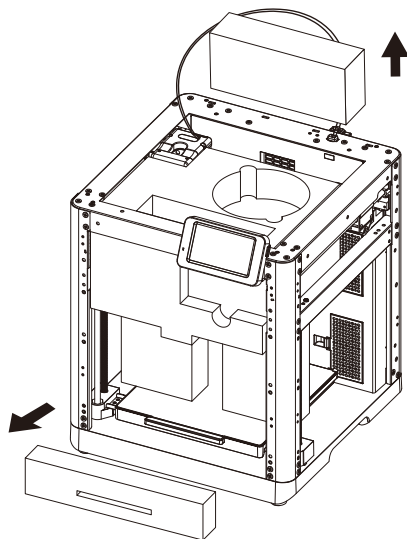

7. 按照箭头方向移动腔体泡棉。

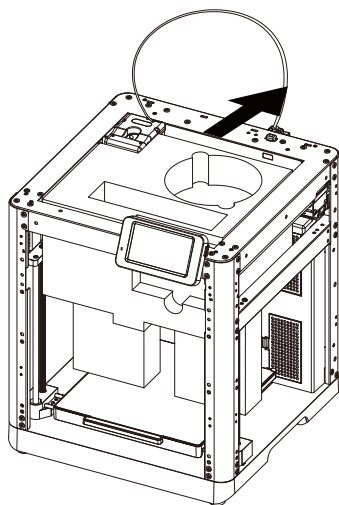

8. 取出泡棉，完成开箱。

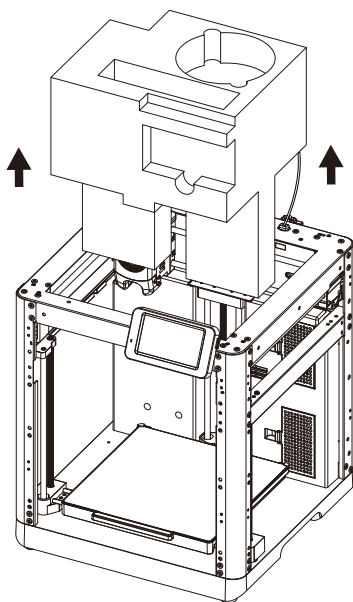

装箱清单

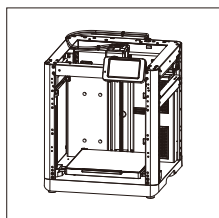

3D打印机

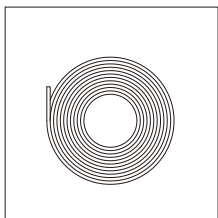

耗材

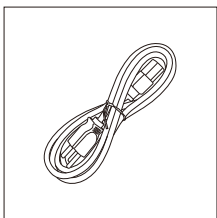

电源线

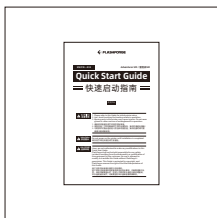

快速启动指南

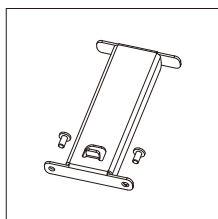

料盘支架
[含两颗螺丝]

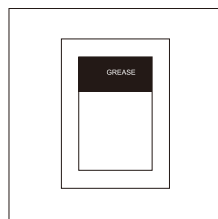

润滑脂

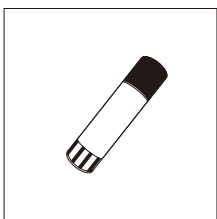

水洗胶

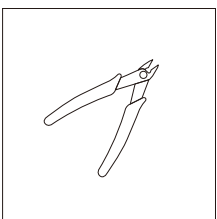

斜口钳

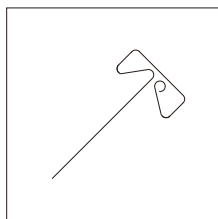

通针

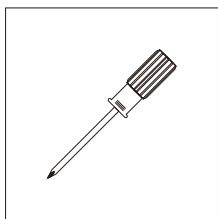

十字螺丝刀

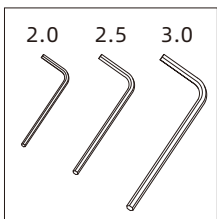

内六角扳手

部件介绍

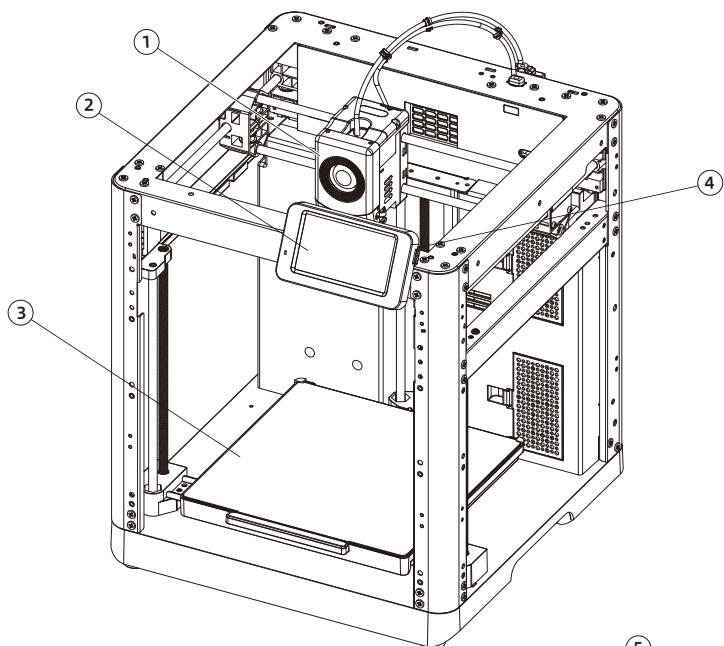

1. 喷头
2. 显示屏
3. 打印平台
4. USB接口
5. 料盘支架安装孔位
6. 丝料检测传感器
7. 网线接口
8. 电源开关
9. 电源接口

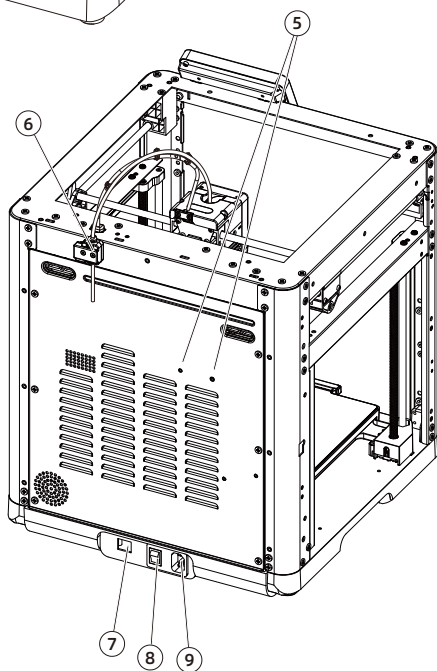

安装耗材架和导丝管

1. 取出配件盒中的两颗螺丝和料盘架。

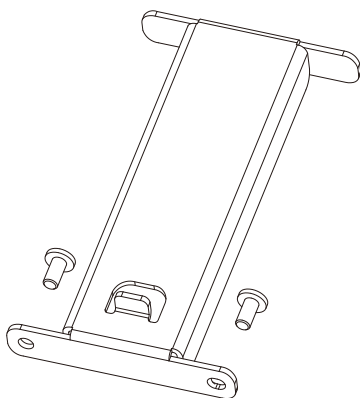

2. 用两颗螺丝将料盘架固定在如图背板位置
(注意：请用2.0mm内六角扳手拧紧固定)。

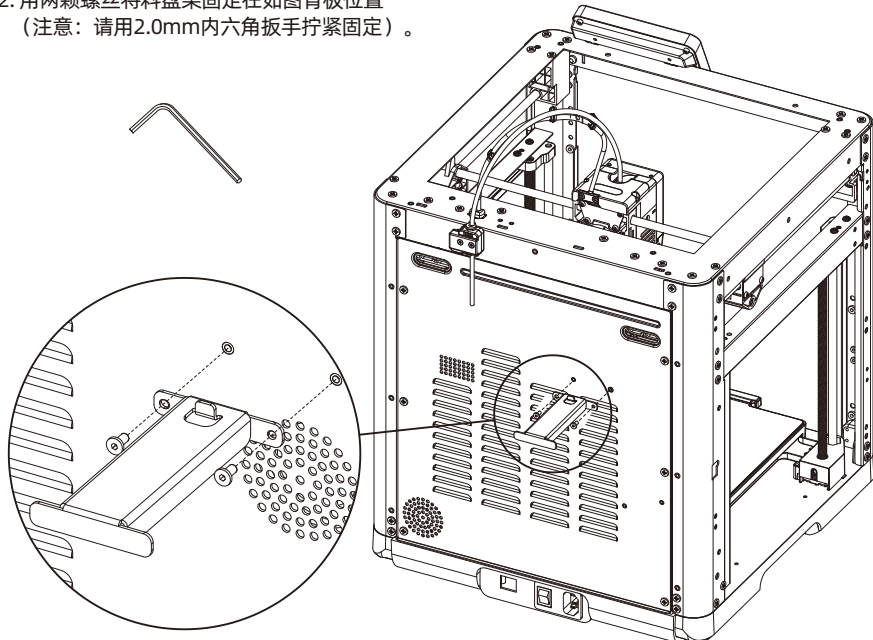

3. 将导丝管前端插入到喷头导管中。

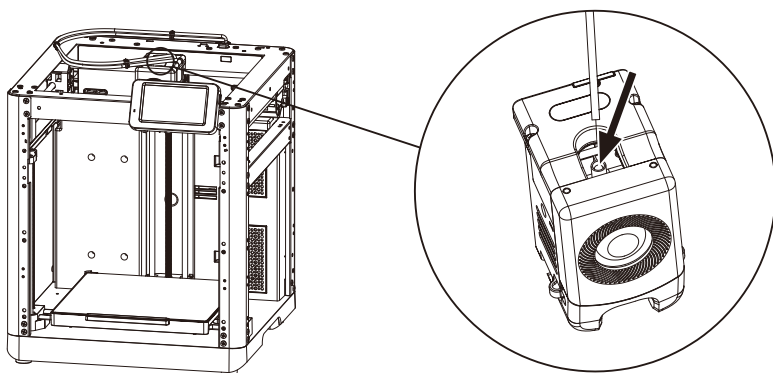

4. 将导丝管后端插入到丝料传感器的卡扣中。

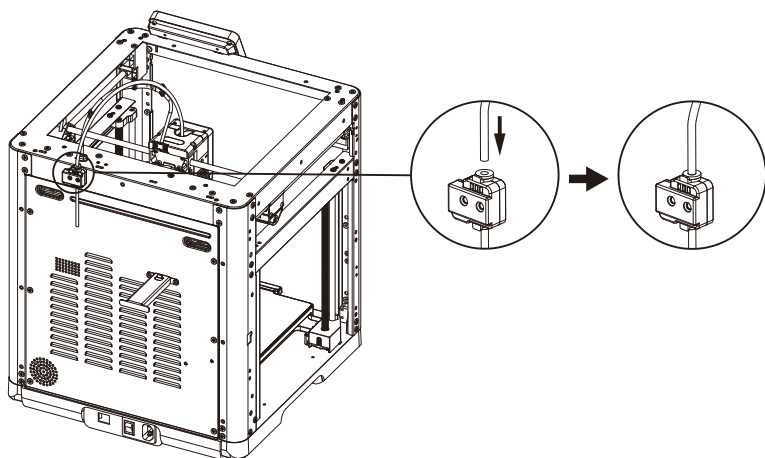

解锁平台

⚠ 注意事项 请确认打印平台无异物!

用2.5mm内六角扳手取下图示中的4颗螺丝（可参照机器上箭头标识），解锁打印平台。

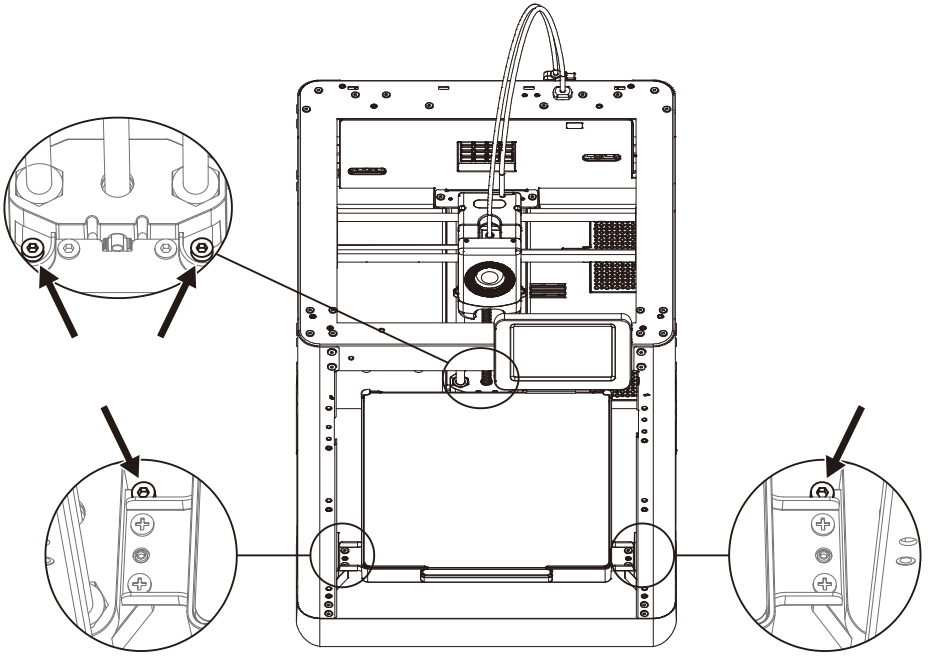

首次打印

* 固件不定期更新，UI界面请以实际为准。

1. 连通电源，打开电源开关点亮屏幕。

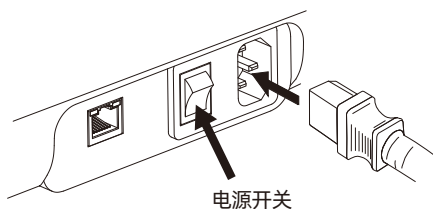

2. 根据屏幕上的开机指引完成界面语言选择。



3. 根据引导打开WiFi开关连接网络，连接成功后会出现提示弹窗。

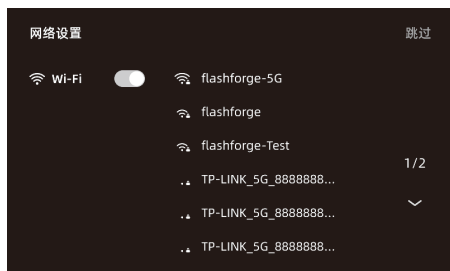
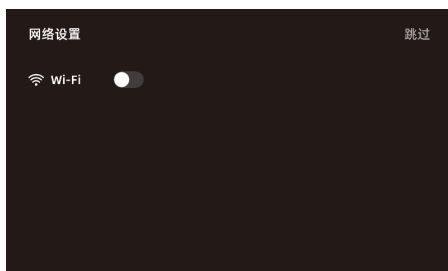
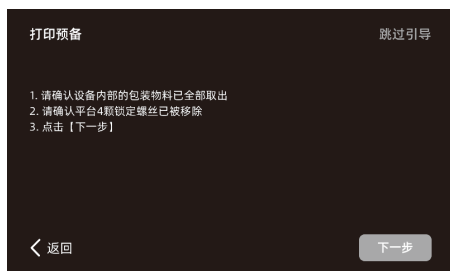

4. 根据引导绑定打印机。（注：此步骤若跳过，后续仍可在设备上操作绑定，详见说明书。）
a. 点击【确定】后出现打印机二维码页面。



- b. 扫码(右图)或通过手机应用商城下载Flash Studio Mobile手机应用，注册您的闪铸账号并登录。



- c. 用Flash Studio Mobile手机应用扫描打印机屏幕上的二维码，将打印机与您的账号绑定。（注：设备出厂时默认设备名称与位置；开机指南完成后，可在设备①中自定义设备名称与位置）



5. 点击[下一步]，机器进行首次校准。校准过程中出现震动和噪音属于正常现象。（注：请将机器放置于稳定的平台面，且校准过程中请勿移动机器。）



6. 根据屏幕开机指引完成耗材安装进丝操作：

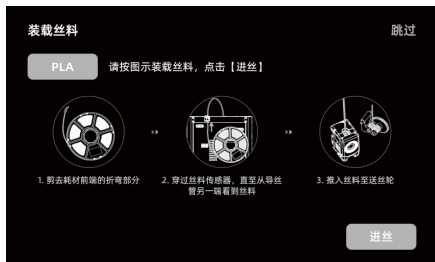

a. 剪去耗材头部弯折部分。

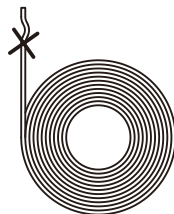

b. 将耗材挂在耗材架上，穿过丝料传感器，直至从导丝管一端看到丝料，将丝料推送到送丝轮处，直到无法再推入（*首次开机请使用PLA耗材进行第一次打印）。

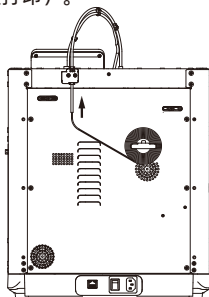
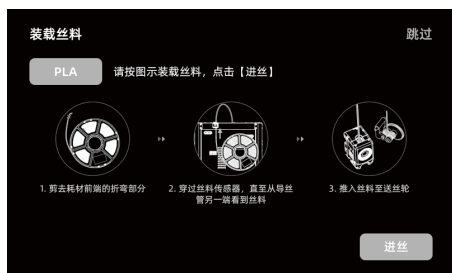

C1. 点击进丝，首次选择默认[PLA]。

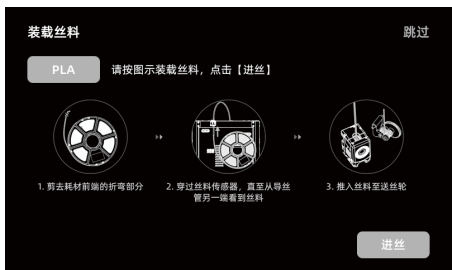

C2. 等待喷头加热。

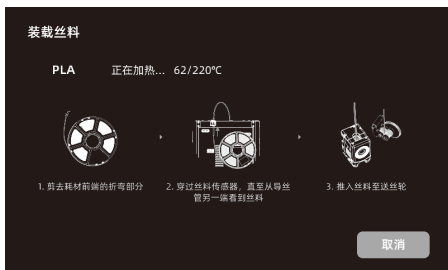

C3. 加热后将开始进丝，直至丝料从喷嘴吐出，说明进丝成功，最后确认导丝管也已完好地插入进丝口。

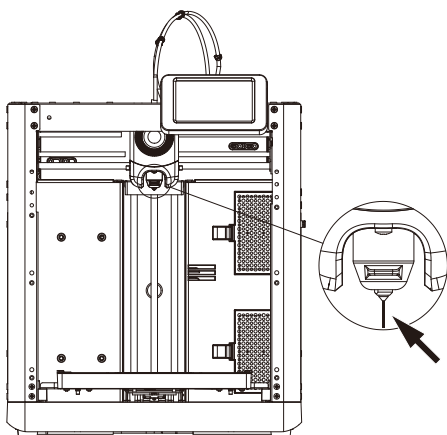

⚠ 注意事项

若一直未见丝料吐出，请用手握住丝料，插入进丝口，点击[返回]重新进行进丝操作。用手感受是否有丝料输送，直到丝料吐出。

7. 清理喷嘴残料以及平台上残余耗材，在打印平台上涂一层胶水，请全幅面涂抹均匀。

注：涂抹胶水有利于改善模型粘附。

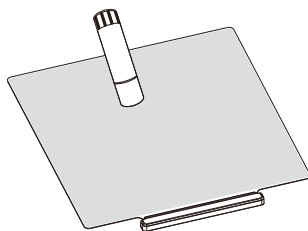

8. 点击[打印]，机器开始首次打印内置文件（该文件的配置参数使用的材料为PLA）。



更多产品相关资料您可以登陆闪铸官网查看。
www.sz3dp.com - [技术支持]

Flash Studio Desktop简介



Flash Studio Desktop

* 图中仅用一种机型示意使用步骤讲解

Flash Studio Desktop是基于Orca开发，并针对Adventurer 5M系列开发自定义功能的一款切片软件。

下载地址

从官方网站<https://www.flashforge.com/pages/download-center>下载最新的切片软件。

1. 打开安装好的Flash Studio Desktop软件。

2. 配置向导。

首次使用软件根据配置向导提示选择您所在的登录地区以及对应机型及使用材料。（注：您可以勾选列表中全部机型及材料类型，以便后续在切片中选择。）



3. 账号登录/注册。
使用您的闪铸账号登录Flash Studio Desktop，如果没有账户，请进行手机注册。（注：Flash Studio Mobile和Flash Studio Desktop使用同一账号。）

4. 新建或打开一个项目并进行切片，您可以在打印机、耗材丝、工艺的配置栏里选择显示对应机型、材料及推荐参数。

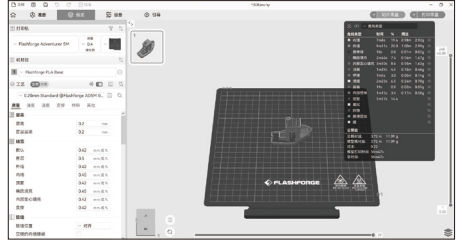

5. 完成切片后，选择打印机并发送打印。

6. 在“设备”界面，对您的打印进程进行远程监控，并可在需要时暂停/停止打印。（注：只有安装并打开摄像头，才可以看到实时监控画面。）

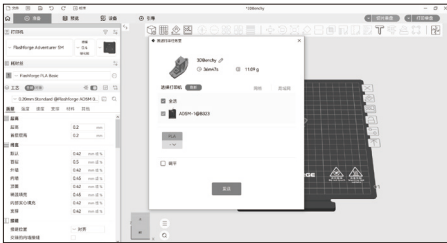

提示

更多软件相关的详细信息和使用教程请访问闪铸官方Wiki查阅。
(<https://wiki.flashforge.com/en/home>)

技术参数

设备名称	冒险家5M
喷头数量	1
打印精度	±0.1mm [以100mm方块为测试基准]
定位精度	X/Y轴：0.0125mm, Z轴：0.0025mm
层厚度	0.1-0.4mm
打印尺寸	220 x 220 x 220mm
喷嘴口径	0.4mm默认[0.6/0.8/0.25mm可选]
打印速度	10-300mm/s
最大加速度	20000mm/s ²
最大移动速度	600mm/s
最高喷头温度	280°C
支持耗材类型	*PLA/*PETG [0.4mm口径] *TPU/PLA-CF/PETG-CF [0.6/0.8mm口径] * 为推荐打印材料
电 源	输入：AC 100~120V/200~240V, 50/60Hz, 350W
设备尺寸	363 x 376 x 413mm [不含显示屏、料盘支架] 363 x 402 x 448mm [含显示屏、不含料盘支架]
净 重	10.8kg
打印连接方式	USB接口/Wi-Fi/以太网
工作温度	15-30°C
兼容的操作系统	Windows 7/8/10/11; Linux支持Ubuntu 20.04及以上版本; Mac OS支持10.9及以上版本
切片软件	Flash Studio Desktop/OrcaSlicer
平台最高温度	110°C
调平方式	一键自动调平
断丝提醒	√
断电续打	√
智能触控液晶屏	4.3英寸
打印平台	PEI柔性钢板

After-sales Service

≡ 售后服务卡 ≡

Zhejiang Flashforge 3D Technology Co., Ltd.



Service: support@flashforge.com
Suggestions and Complaints: mkt2@flashforge.com



Web: flashforge.com | enterprise.flashforge.com



Address: Floors 2-4, Building B, Huaxing Development Building, No.328 Wen'er Road, Xihu District, Hangzhou City, Zhejiang Province, China

浙江闪铸集团有限公司



服务热线: 400 8866 023



建议与投诉: mkt2@flashforge.com



网址: www.sz3dp.com



地址: 浙江省杭州市西湖区文二路328号华星发展大厦B座2-4楼

⚠ Note

The one who sells you the printer should be responsible for your after-sales service.

1. Flashforge grants all end-users a 12-month limited warranty for all Flashforge 3D printers (except the Flashforge extruder) and a 3-month warranty for Flashforge FFF Extruder.
2. If Flashforge 3D printer fails during normal and proper use within the warranty period (judged by Flashforge engineers), Flashforge will provide users with free maintenance services or remote after-sales support.
3. The warranty period starts from the outbound date, or starts from the invoice date if clear and confirmed invoice is provided.
4. Flashforge will repair or replace only the defective parts with new or reconditioned parts or products that are functionally equivalent or superior to those originally supplied. If a part is repaired or replaced during the warranty period, the warranty period still remaining for the entire printer will apply to this part.

⚠ 注意事项

闪铸科技采用谁销售谁服务的原则，如您的3D打印机是在非闪铸官方平台购买，请向您购买的商家获取相关支持

1. 闪铸科技所有3D打印机均为用户提供12个月整机有限质保。其中FFF技术3D打印机的喷头质保时间为3个月。
2. 质保期内若设备出现非人为损坏（由闪铸工程师评定），您将获得免费配件及售后技术支持。
3. 售后服务周期以产品出厂日期为起始。如能提供清晰的发票，则以发票开具日期为起始。
4. 维修零配件可能为非全新配件，但甲方保证配件功能完全正常。维修配件质保时间与其整机质保时间相同。

Parts Excluded from This Warranty

Build Tape / Build Plate / Acrylic Cover / SD Card / USB Stick / USB Cable / Filament / Filament Spool / Glue / Resin Vat / Film / Rinse Bucket / Gloves / Plastic Scraper / Metal Scraper / Brush / Allen Wrench (2.5mm*1/3mm*1/5mm*1) / Stamping Wrench / Tools Bag / Accessories

*FFF extruder kit shall be purchased independently due to upgrading.

WHAT IS NOT COVERED

- ◆ Unable to provide valid After-sales Service Card or Serial No. (Including but not limited to lost, alter or fuzzy cannot be confirmed);
- ◆ FFF commercial printers out of warranty period or over 1000 working hours; FFF consumer printers out of warranty period or over 400 working hours;
- ◆ Damage(s) caused by improperly or incorrectly performed modifications, alterations or repair;
- ◆ Damage(s) due to operation under improper environment (damp, wet or other extreme weather);
- ◆ Exterior scratch or flaw caused by abrasion, aging or normal use;
- ◆ The warranty period of printer or part has expired;
- ◆ Damage(s) caused in service shops unauthorized by Flashforge;
- ◆ Damage(s) caused by improperly installation, use or operation;
- ◆ Damage(s) caused by abuse(overloaded working), misuses;
- ◆ Damage(s) caused by using unauthorized spare parts or poor quality filament (Recommended to use Flashforge filament);
- ◆ Damage(s) caused by using 3rd party software;
- ◆ Damage(s) caused by force majeure (such as a lightning strike, fire, earthquake, floods or any other event beyond human control);
- ◆ Damage(s) caused by using 3rd party parts;



After-sales Service Registration Form

Series No.: _____ Purchase from: _____

Fault Description: _____

Tel.: _____ Contact: _____

Add.: _____

- ❗ Please fill in this form carefully, cut out this form and mail it back to Flashforge together with the printer, or download this form from www.flashforge.com, fill in this form and send it to support@flashforge.com. After-sales service shall not be provided without this form.
- ❗ Please contact your printer's reseller to get After-sales service help if your printer is not purchased on official Flashforge website.

以下配件不列入质保范围

平台贴纸 / 平台金属板 / 平台玻璃板 / 亚克力罩 / SD卡及U盘 / USB线 / 打印耗材 / 丝盘轴 / 溶液盒 / 薄膜 / 打印平台 / 遮光罩清洗盒 / 塑料铲刀 / 金属铲刀 / 刷子 / 清洗手套 / 内六角扳手(2.5mm*1/3mm*1/5mm*1) / 开口扳手 / 工具包及包内工具。

*由于FFF产品喷头会有迭代升级，喷头升级套件需单独购买。

以下情况不在质保范围内

- ◆ 无法提供有效质保卡或序列号(遗失、涂改、模糊无法确认)；
- ◆ 整机及部件已经超过质保有效期；
- ◆ FFF商用设备运行总时长超过1000小时，FFF消费级设备运行总时长超过400小时；
- ◆ 设备曾经在未经闪铸授权的维修店维修；
- ◆ 设备在非产品规定的工作环境下使用而造成的设备故障或损坏；
- ◆ 设备正常磨损、老化或因操作造成的外观划痕或瑕疵；
- ◆ 由于使用非闪铸指定的软件而造成的设备故障或损坏；
- ◆ 由于使用其它品牌部件造成的设备故障或损坏；
- ◆ 由于私自对设备进行改装而造成的设备故障或损坏；
- ◆ 由于错误安装、使用而造成的设备故障或损坏；
- ◆ 由于滥用(包括超出工作负荷)、误用而造成设备故障或损坏；
- ◆ 由于使用低质量耗材而造成的设备故障或损坏(建议使用闪铸官方耗材)；
- ◆ 由于维护不当(受潮、发霉或暴露在极端气候)造成的设备故障或损坏；
- ◆ 由不可抗因素(如火灾、地震、雷击、水灾等)造成的故障或损坏。



售后服务登记表

序列号： _____ 从何处购买： _____

故障描述： _____

联系电话： _____ 联系人： _____

地址： _____

❗ 请务必仔细填写此表，剪下并随机器寄回闪铸科技，或在闪铸官网(官网地址见反面)下载此表发送给support@flashforge.com。
未填写此表将无法进行售后服务。

❗ 如您非闪铸官方平台购买机器，请直接联系您购买的商家获取售后支持。



Follow us

Zhejiang Flashforge 3D Technology Co., Ltd.

Address: Floors 2-4, Building B, Huaxing Development Building,
No.328 Wen'er Road, Xihu District, Hangzhou City, Zhejiang Province, China

Service: support@flashforge.com

Suggestions and Complaints: mkt2@flashforge.com

Web: flashforge.com | enterprise.flashforge.com

浙江闪铸集团有限公司

地址：浙江省杭州市西湖区文二路328号华星发展大厦B座2-4楼

服务热线：400 8866 023

建议与投诉：mkt2@flashforge.com

网址：www.sz3dp.com